



---

**Turbine Drive Water-Reels®  
Engine Drive Slurry-Reels**

---

T37A

E37A

# Parts Manual

Serial No. 330,000 - 349,999



**AG-RAIN®**

700 S. Schrader Ave.  
Havana, Illinois 62644  
Phone: 309-543-4425  
Fax: 309-543-4945

**PARTS MANUAL**  
**Turbine/Engine Driven 37A**  
**S/N 330,000-349,999**

	<b>Assembly</b>	<b>Page</b>
	Running Gear Assembly	3-4
	Cradle Assembly	5-6
	Spool Assembly	7-8
	Levelwind Assembly	9
	Shut Off/Boom Assy.	10
	Shield Group	11
	Turbine Assembly	12-15
	Gearbox	16-17
	Drive Train Group	18-20
	Sprinkler Cart Assembly	21-23
	Decal Group	24
<b>Serial # 330,000-339,999</b>	Engine Drive Assembly	25-29
	Oil Circuit Assembly	30-31
<b>Serial # 340,000 +</b>	Engine Drive Assembly	32-34
	Safety Shut Down	35

Notes:

For Parts That Are Described As "Left" Or "Right" The Water Inlet Side Of The Machine Is Considered The Right Side.

Items Such As Common Fasteners, Grease Fitting, And Other Small Parts Easy To Acquire Locally Are Not Listed.

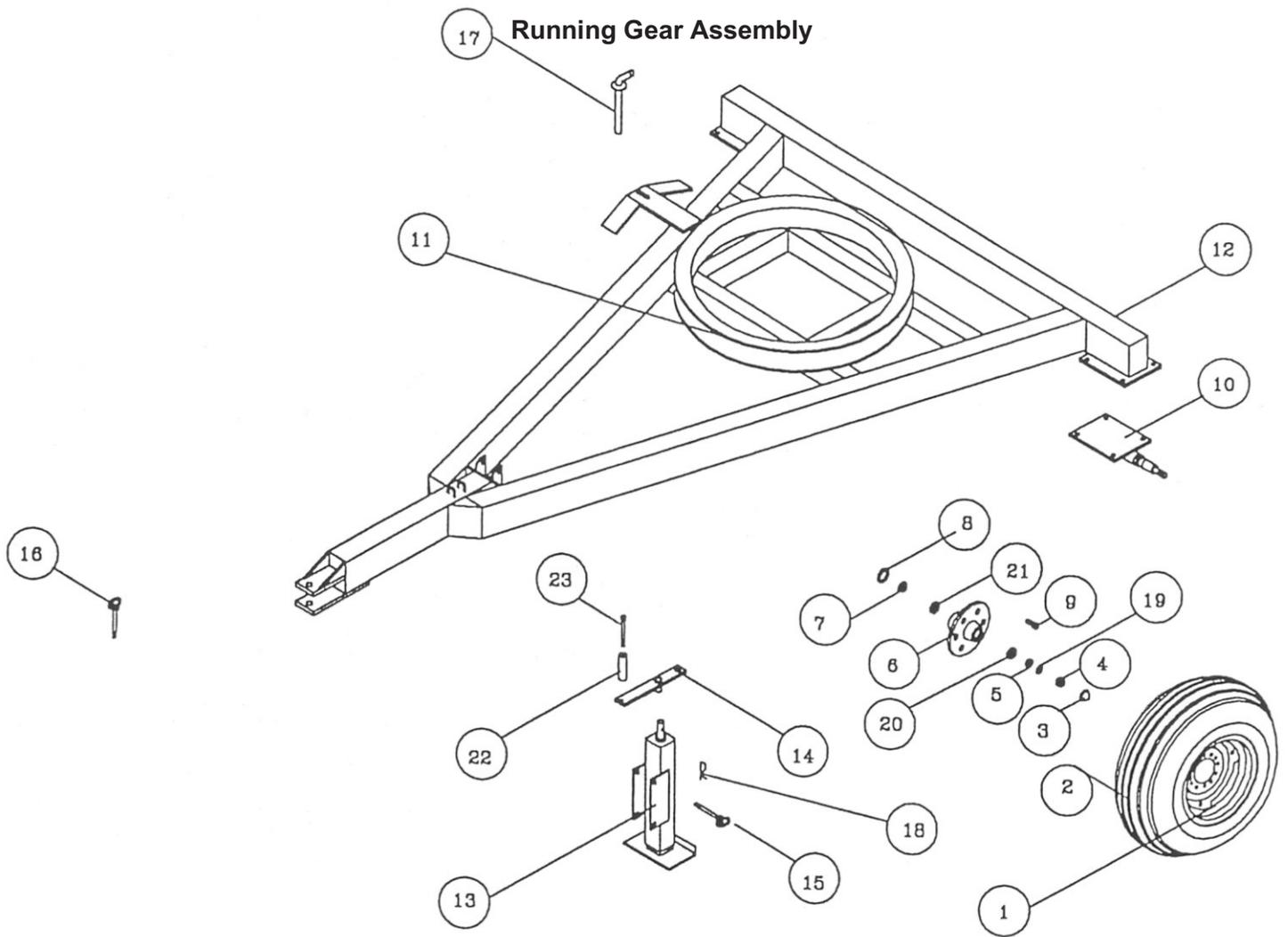

Running Gear Assembly			
No.	Part Number	Description	Qty.
1	526-5138-1	Wheel, 6 Bolt x 15" x 10"	2
2	526-5137-0	Tire, 12.5L-15, 12 Ply	2
3	589-0206-0	Cap, Hub Wilton 90903	2
4	589-0207-0	Nut, 7/8" NF Slotted Wilton 912952	2
5	589-0204-0	Bearing, Outer LM25877	2
6A	589-0199-0	Hub, with Races Only Wilton 280581	2
6B	226-1598-2	Hub, With Races, Brng, Sl, and Hub Cap (Not Shown)	2
7	589-0203-0	Bearing, Inner LM25590	2
8	589-0205-0	Seal, Grease CR20148	2
9	589-0202-0	Bolt, 9/16 Lug Wilton 9135381	12
10	588-0397-1	Spindle Assembly	2
11	020-9955-4	Bearing, Turntable	1
12	592-0232-0	Chassis	1

17 Running Gear Assembly

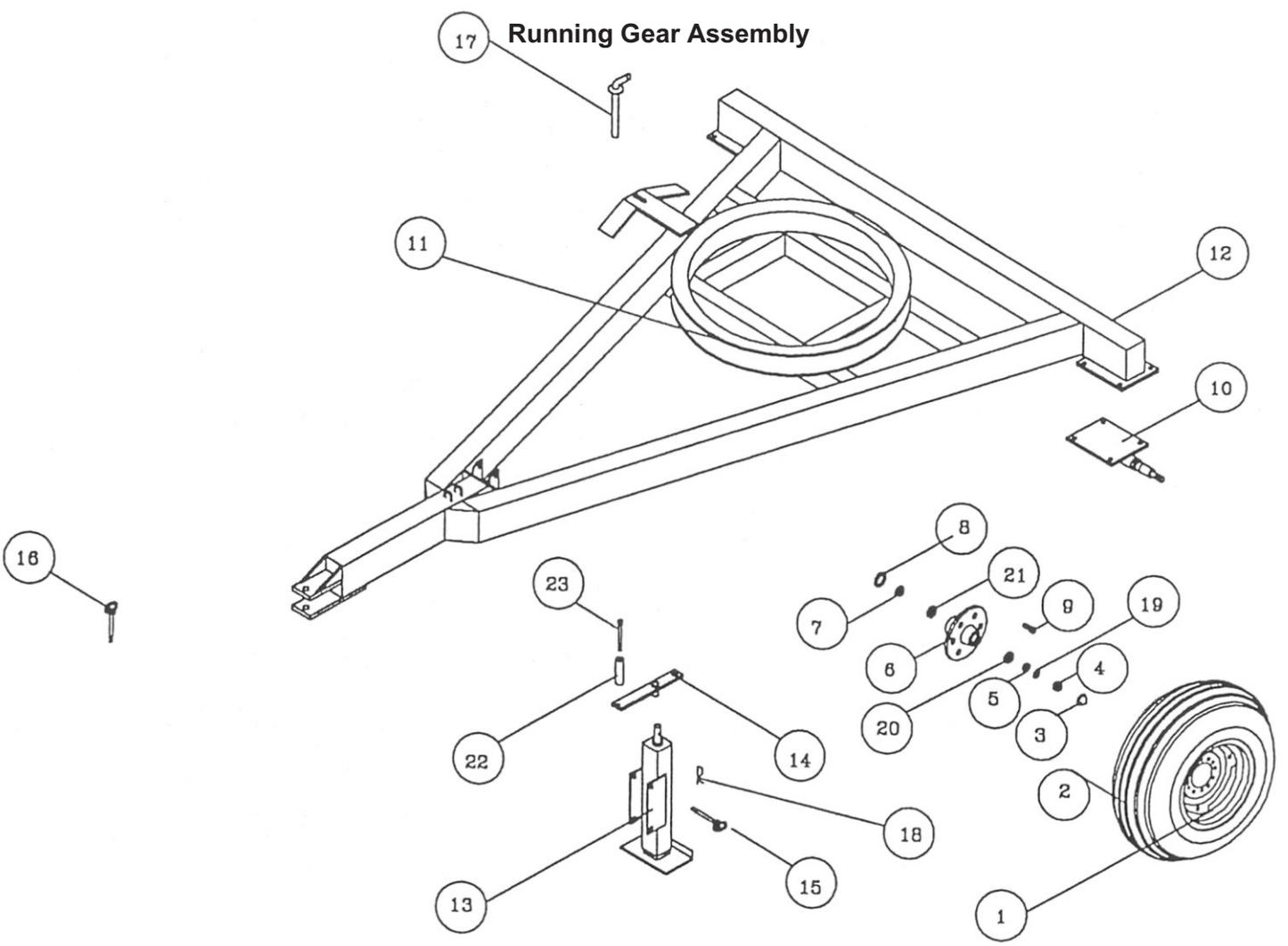

13A	584-0330-0	Jack Assembly	1
13B	584-0332-8	Screw Assembly w/nut (Jack Repair Part)	1
13C	584-0330-9	Thrust Bearing (Jack Repair Part)	1
14	594-0330-0	Crank, Jack	1
15	558-3281-1	Pin, 3/4 x 4-1/8 Hitch	1
16	523-5866-0	Pin, 3/4 x 6-1/2 Hitch	1
17	595-0483-0	Pin, 3/4 x 5-3/4" Hitch	1
18	561-0204-0	Hair Pin	1
19	589-0208-0	Washer, Spindle 91307 Wilton	2
20	589-0201-0	Race, Outer LM25821	2
21	589-0200-0	Race, Inner LM25520	2
22	594-0324-0	Handle Bearing	1
23	562-3136-1	Screw, Allen Cap 1/2" x 5"	1



### Cradle Assembly

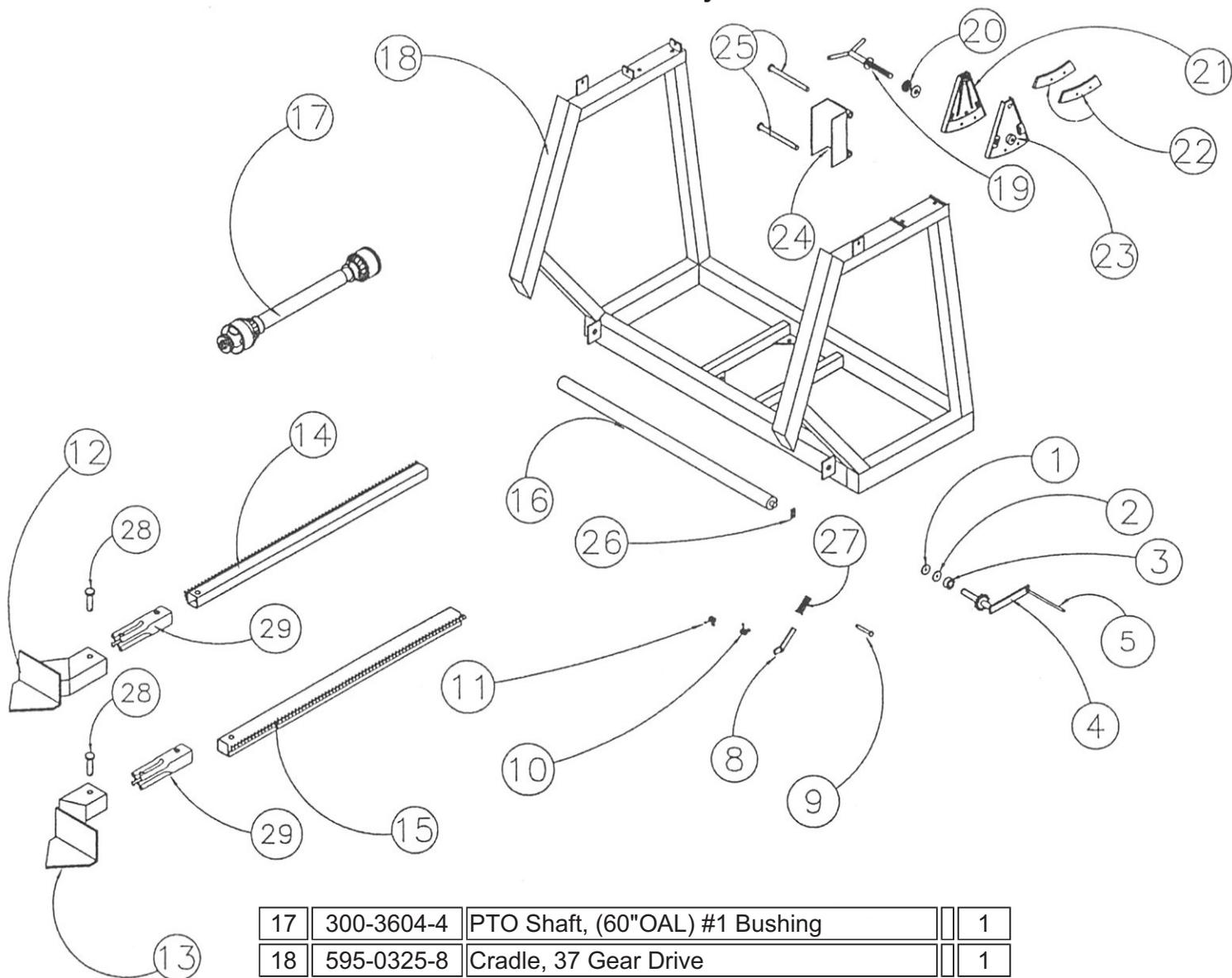

17	300-3604-4	PTO Shaft, (60"OAL) #1 Bushing	1
18	595-0325-8	Cradle, 37 Gear Drive	1
19	022-0159-0	Brake Control Screw	1
20	022-0156-0	Washer	2
21	022-0158-1	Brake Plate	1
22A	022-0454-0	Slide (Brake Pad)	2
22B	550-7010-0	Bolt, Brass 8-1.25mm x 20mm (Not Shown)	4
23	022-0157-1	Brake Plate Threaded	1
24	022-0448-3	Brake Mt. (FF1)	2
25	022-0453-3	Pin, Brake Support	1
27	022-0556-0	Hand Grip	2
28	020-9905-3	Pawl Holder Pin w/washer	2
29	594-0317-0	Extension, Stabilizer Leg	2

## Spool Assembly

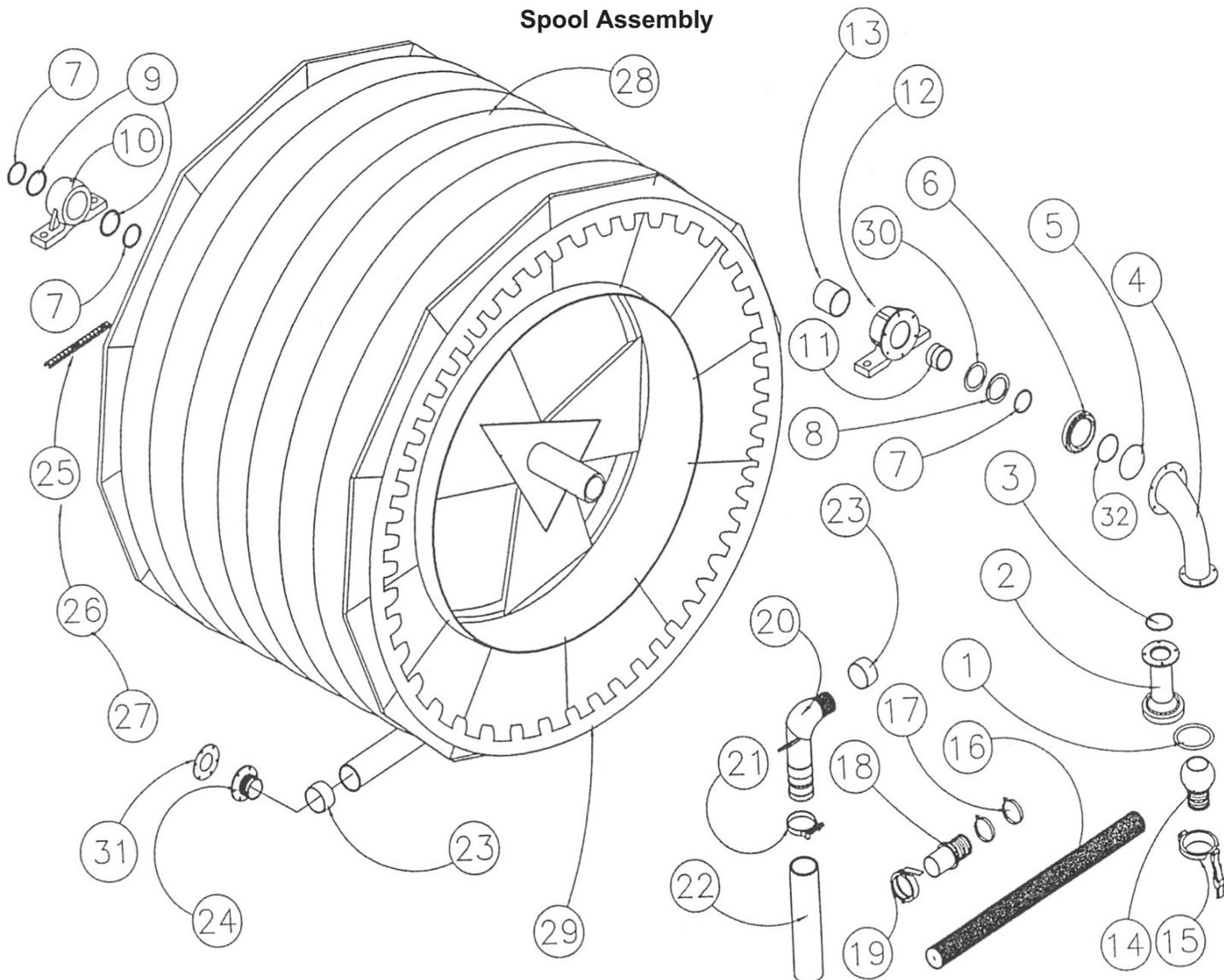

Spool Assembly				
No.	Part Number	Description	Qty.	
1	588-0223-3	O-Ring, 4"	1	
2	022-0483-0	Entry Fitting	1	
3	022-0484-0	O-Ring	2	
4	022-0655-1	Upper Feeding Elbow 37	1	
5	597-0328-0	O-Ring 6.012" OD x .139" CS	1	
6	596-0369-1	Housing, Sealing 37	1	
7	022-0008-0	Snap Ring	3	
8	022-0009-0	Washer, Thrust	1	
9	022-0038-1	Spacer	2	
10	022-0015-0	Bearing, Spool	1	
11	593-0245-0	Ring Nut, Slip Joint	1	
12	022-0013-0	Bearing	1	
13	022-0487-1	Sleeve (FF1)	1	
14	588-0256-1	Hose End Outlet 4" Ball	1	
15	588-0023-1	Lever Ring 4" 451 108mm	1	

## Spool Assembly

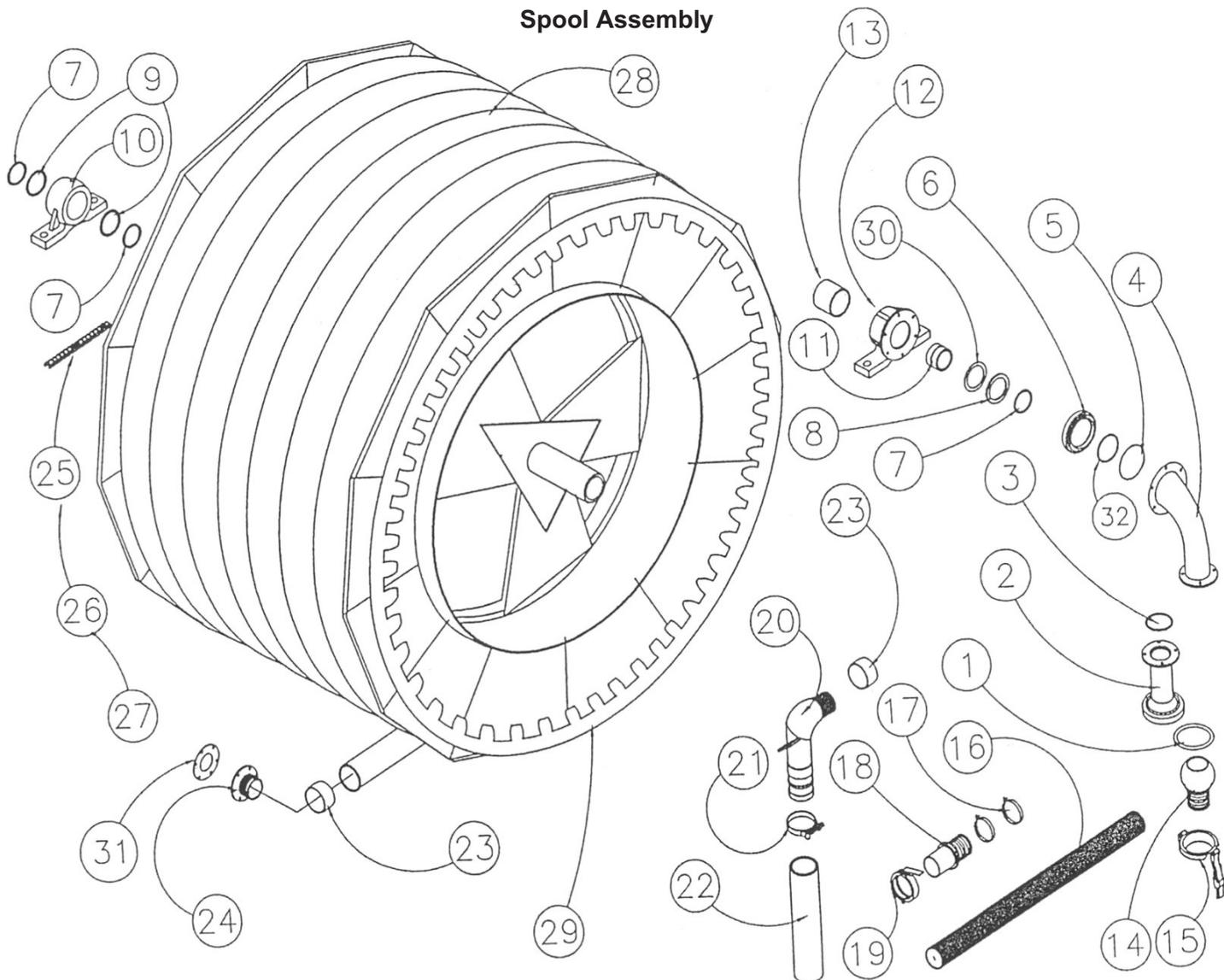

16	252-4962-0	Hose, IRR Supply 4"	Ft.	30
17	030-1924-0	Clamp, Supra 104-112		4
18	588-0266-0	Hose End Inlet 4" Ringlock		1
19	400-4927-0	Band, Ring Lock "		1
20	020-0310-7	Elbow, PE Tube		1
21	030-1925-8	Clamp, Supra 112mm -121mm		4
22	020-9911-1	Hose		1
23	020-9911-5	Hose Band		2
24	020-0311-9	Tube End, 110mm x Flange	Ft.	14
25	020-0114-0	Chain, 1/2" Pitch		1
26	022-0111-0	Link, Connector 1/2" Pitch		1
27	022-0110-0	Link, Offset 1/2" Pitch		1
28	584-0173-1	Tube, PE 110mm x 3.7 ID x 1110 Ft. (Standard)		1
29	022-0458-1	Spool, Base FF1 Gear Drive		1
30	022-0010-0	Washer, Wear		1
31	020-9920-2	Gasket		1
32	465-4848-1	O-Ring 4-3/4 x 4-1/4 x 1/4		1

## Levelwind Assembly

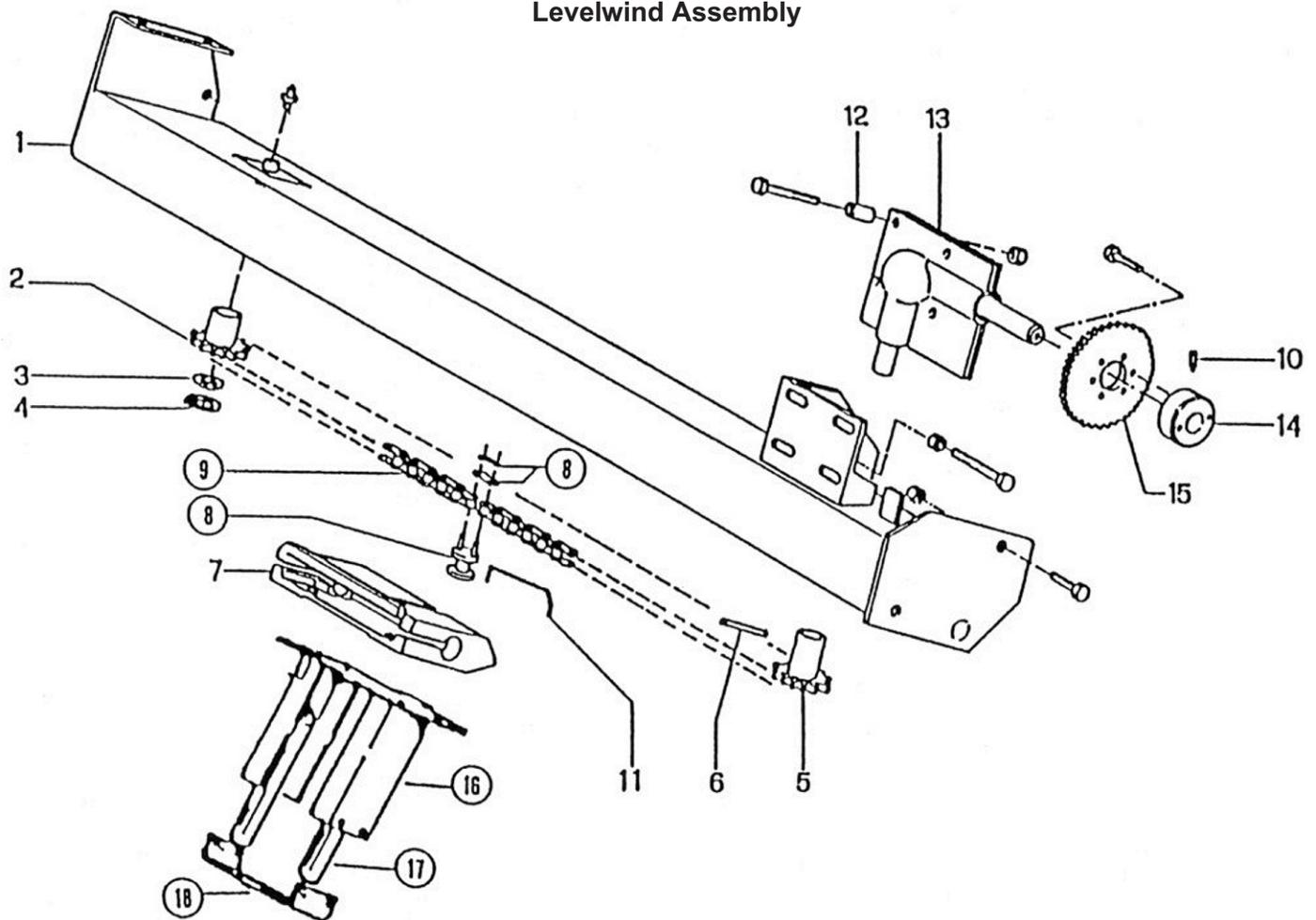

Levelwind Assembly			
No.	Part Number	Description	Qty.
1	022-0016-0	Frame, Levewind (Base FF1)	1
2	020-9914-8	Sprocket, 10 Tooth Idler	1
3	553-0628-0	Spacer, 1 1/2 x 1 x 18 GA	1
4	526-6254-0	Snap Ring	1
5	021-9915-1	Sprocket, 10 Tooth Driver	1
6	589-0214-0	Spring Pin, 7mm x 45mm	1
7	020-0014-1	Fork Support	1
8	020-9914-3	Guide Link	1
9	020-0486-5	Chain, 1/2" x 112 Rollers (Base FF1)	1
10	020-0015-2	Set Screw	1
11	020-0077-6	Retaining Clip	1
12	020-0108-4	Spacer	1
13	020-0108-5	Gearbox	1
14	020-0015-3	Hub, Sprocket	2
15	020-9915-8	Sprocket, 1/2 Pitch x 36 Teeth	1
16	020-0415-9	Fork	1
17	020-0486-1	Roller, Vertical	2
18	020-0414-6	Tube Retainer	1
19	022-0104-0	Lvl Wnd Assm. Cmpl't w/o # 16,17,18 (Not Shown)	1

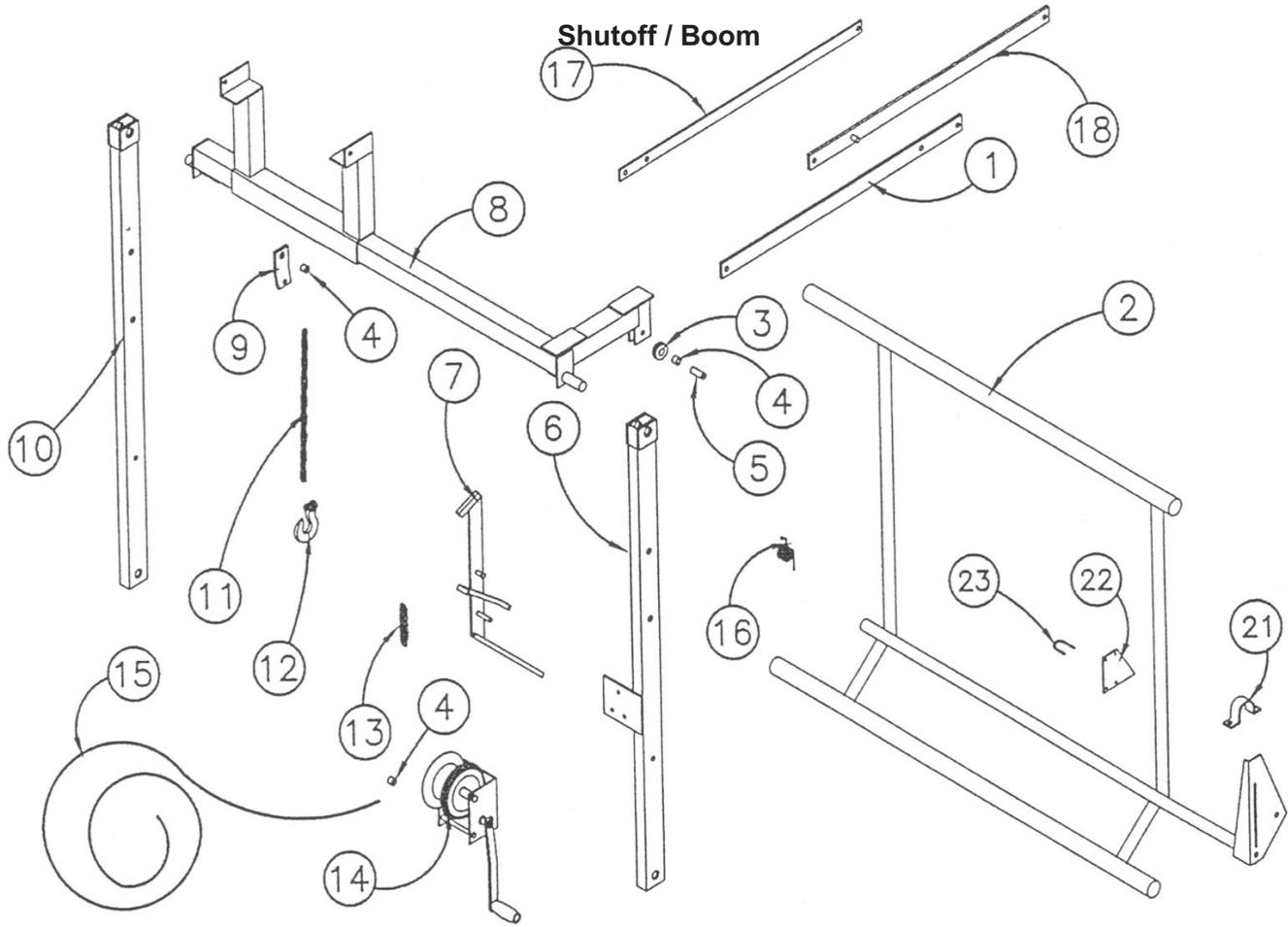

No.	Part Number	Description		Qty.
1	595-0067-0	Brace, Boom		2
2	022-0493-1	Shut Off Bar FF1		1
3	402-4906-0	Pulley, WRP 17/32		1
4	325-5191-0	Bushing, .84 x .56 x .62 Long		4
5	595-0054-0	Bushing, 3/4 x .51 x 1.75		1
6	594-0339-1	Arm, Lift Right		1
7	594-0476-0	Boom, Catch		1
8	594-0349-1	Boom, Lift Assembly		1
9	595-0073-0	Link, Boom Chain		2
10	594-0336-1	Arm, Lift Left		1
11	850-4060-0	Chain, 3/8 Proof Coil 21 Links	Ft.	1.8
12	523-5565-0	Hook, Clevis Slip		2
13	450-3536-0	Spring, TNSN. 1 x 6		1
14	400-4855-1	Winch, Fulton K1550		1
15	750-4844-0	Cable, 1/4-7 x 19 GAL	Ft.	12
16	022-0016-6	Spring		1
17	595-0069-0	Transport Strap		2
18	595-0068-0	Brace		2
20	022-0163-0	Cap Plug (Not Shown)		4
21	022-0061-1	Retainer		1
22	597-0342-0	Comp. Stop		1
23	022-0665-0	U-Bolt		2

### Shield Group

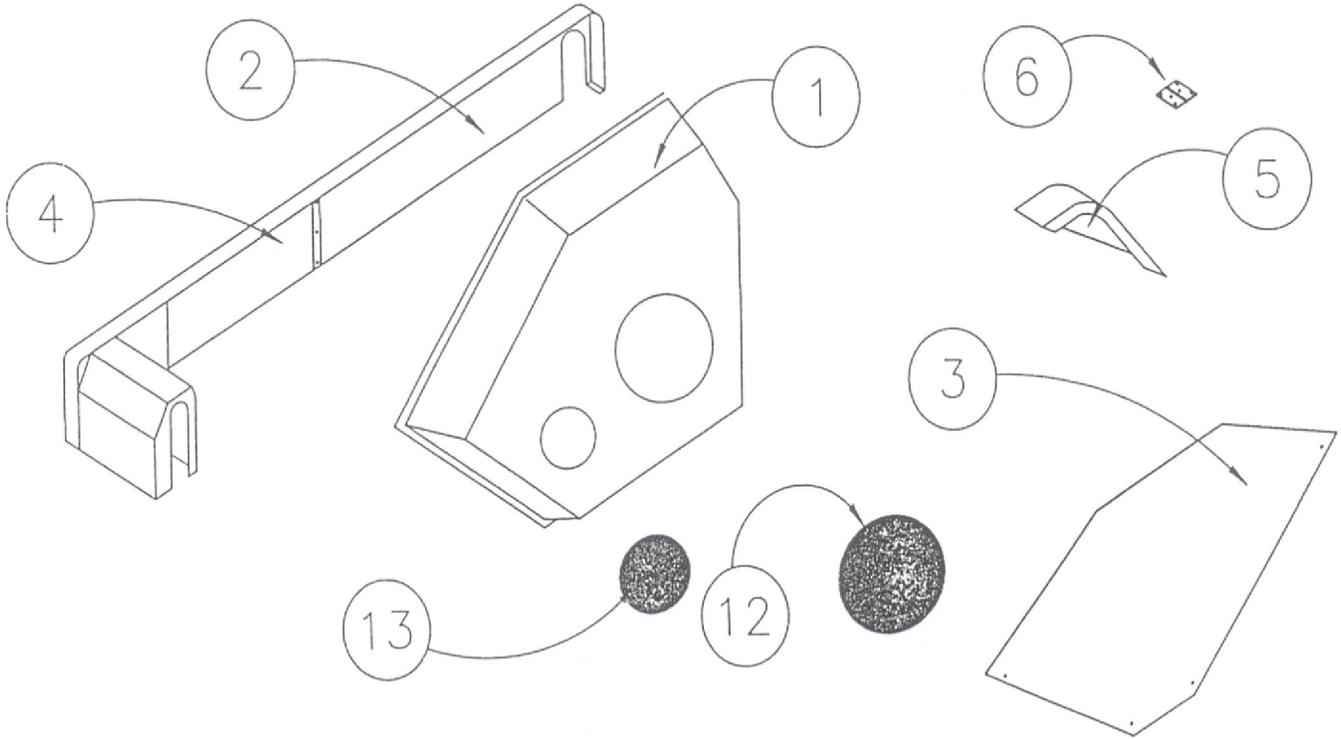

Shield Group			
No.	Part Number	Description	Qty.
1	022-0538-1	Hood	1
2	022-0123-2	Shield, Chain	1
3	593-0039-1	Shield, 37A Spool	6
4	022-0122-0	Shield Levelwind	1
5	022-0388-0	Shield, Belt	1
6	022-0389-0	Hinge	1
12	022-0539-0	Door	1
13	022-0750-0	LID, HOOD	1
14	597-0281-0	Rubber Latch (Not Shown)	3

## Turbine

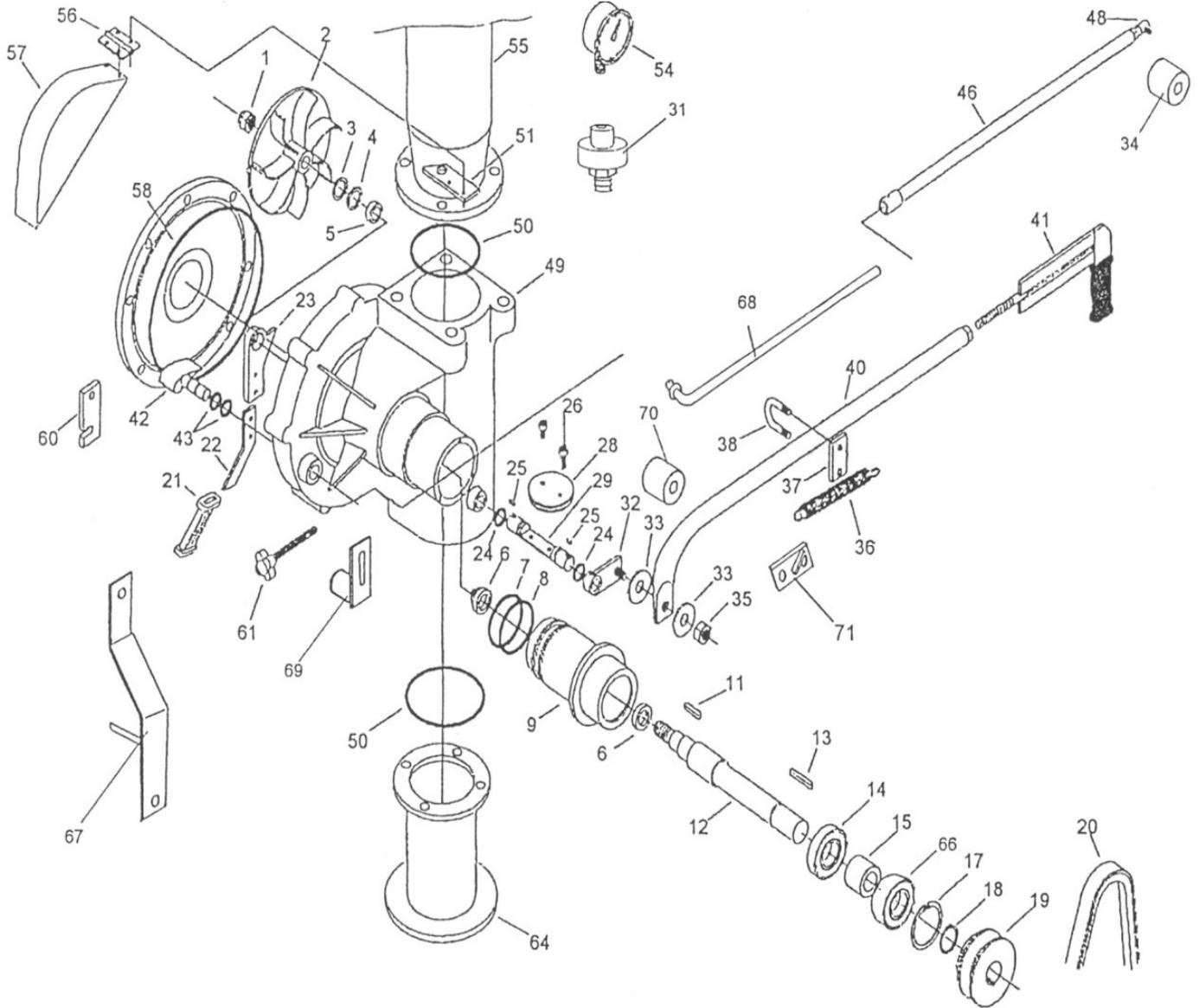

Turbine			
No.	Part Number	Description	Qty.
1	022-0198-0	Nut, Self Locking Thin 14 x 1.5mm	1
2	022-0199-3	Impeller 6.77 OD x .87 Vane Height	1
3	022-0543-0	Shim, Dia 16.2 x 23.8 x .25	2
4	022-0300-2	Spacer 15mm (.6" Long)	1
5	022-0544-0	Spacer, Dia 25E x 161 SP1.8	1
6	022-0545-0	Seal 20 x 6 Mechanical	1
7	022-0546-0	O-Ring 2.30" id x .103" c/s	1
8	022-0546-1	O-Ring 2.362" id x .103" c/s	1
9	022-0548-0	Turbine Housing T200	2
11	022-0337-0	Key 5 x 5 x 10	1
12	022-0550-0	Impeller Shaft	1
13	022-0551-0	Key 6 x 50	1
14	022-0167-0	Bearing, 6204 2RS	1
15	022-0522-1	Spacer 1.8" Long	1
17	022-0324-0	Retaining Ring i47	1

### Turbine

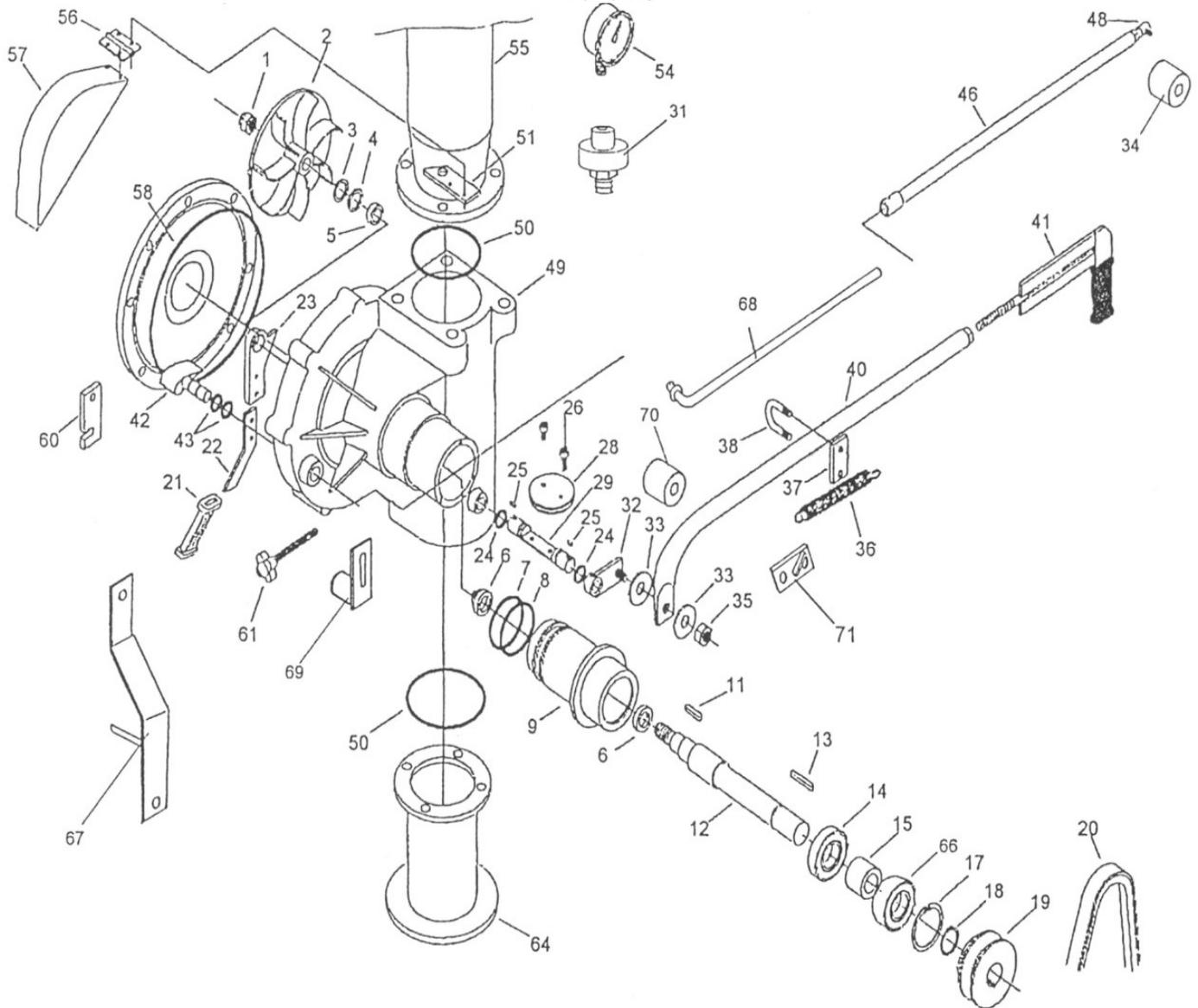

18	022-0323-0	Retaining Ring E20	1
19	022-0592-0	Pulley 3 Step	1
20	022-0555-2	Belt A83	1
21	022-0556-0	Hand Grip	1
22	022-0557-0	Plate By-Pass Lever	1
23	022-0558-0	Lever	1
24	022-0559-0	O-Ring 120 15,54 x 2.62	2
25	022-0319-0	Key, 6 x 10mm	2
26	022-0305-0	Screw, 6 x 16 Inox	2
28	022-0562-0	Disc, By-Pass	1
29	022-0563-2	By-Pass Shaft	1
31	596-0041-0	Gauge Protector	1
32	022-0564-0	By-Pass Lever	1
33	022-0565-0	Washer 10 x 30	1
34	022-0660-0	Spacer, 1" OD x 2.4 " Long x 8mm Threads	1
35	551-7001-1	Nut, M10 Nyloc	1
36	022-0318-0	Spring	1

### Turbine

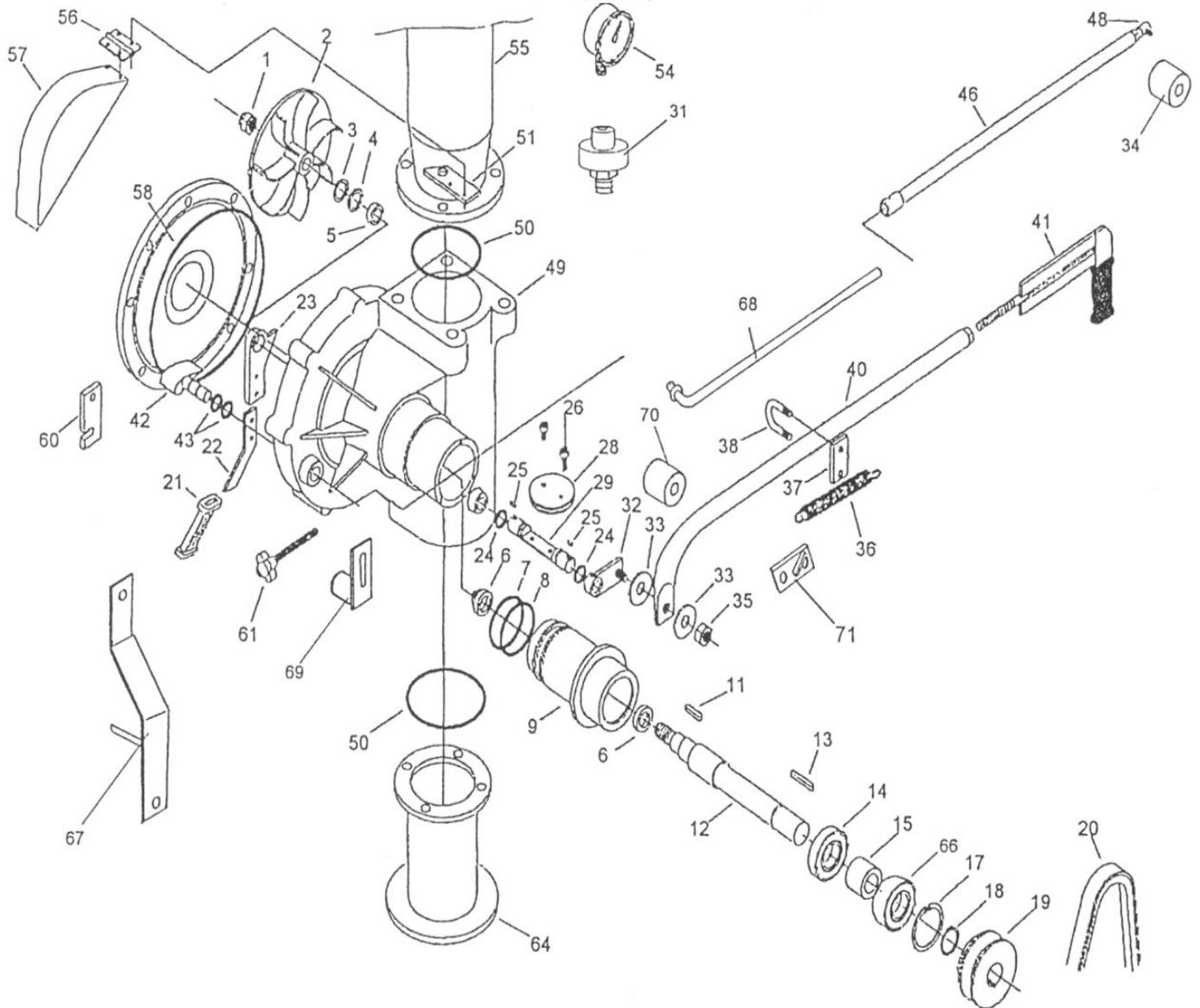

37	022-0317-0	Spring Support	1
38	022-0312-0	U-Bolt DIA 8	1
40	022-0311-1	By-Pass Rod	1
41	022-0316-2	Tie Rod (FF1)	1
42	022-0566-0	Regulator Flap with Pin	1
43	022-0331-0	O-Ring 108	2
46	022-0569-2	By-Pass Rod (FF1)	1
48	022-0341-0	Rod End	
49	022-0302-1	Turbine Body T200	1
50	022-0484-0	O-Ring	2
51	022-0571-0	Support	1
54	586-0675-0	Gauge 0-300	1
55	022-0655-1	Upper Feeding Elbow 37	1
56	022-0389-0	Hinge	1
57	022-0388-0	Shield, Belt	1
58	022-0572-0	O-Ring i286x 3.53	1
60	022-0573-0	Stop Plate	1

### Turbine

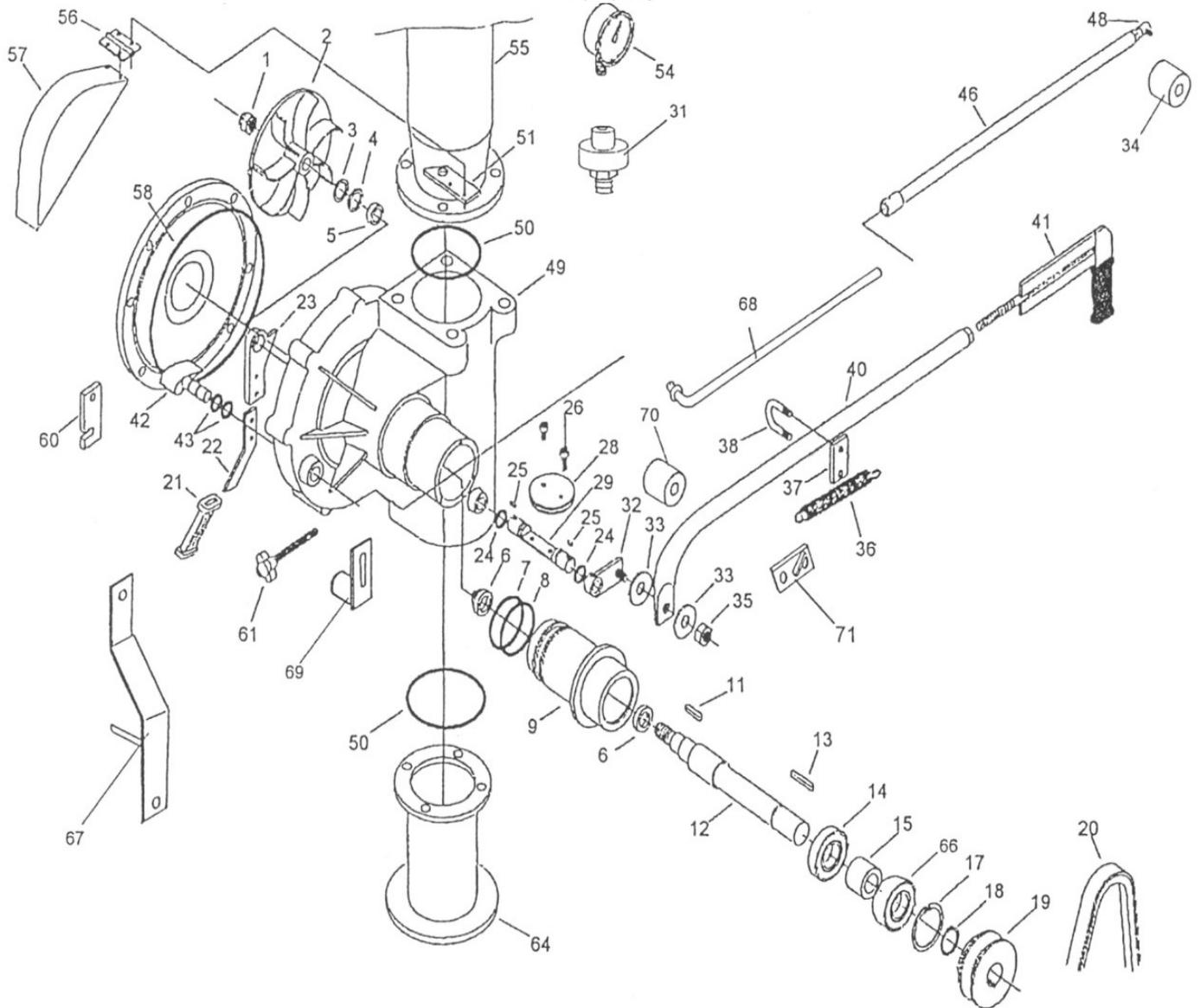

61	022-0391-0	Knob	1
64	022-0308-1	Lower Feeding Elbow	1
66	022-0167-1	Bearing, 5204 2RS	1
67	022-0648-0	Arm Comp.	1
68	022-0649-0	Link, Comp	1
69	022-0650-0	Loop, Comp	1
70	022-0661-0	Spacer 10mm Threads	1
71	597-0311-1	Arm, Extension	1
	990-7030-0	Overhaul Kit Runner Shaft Assm. 25/120 (Not Shown)	1

## Gearbox

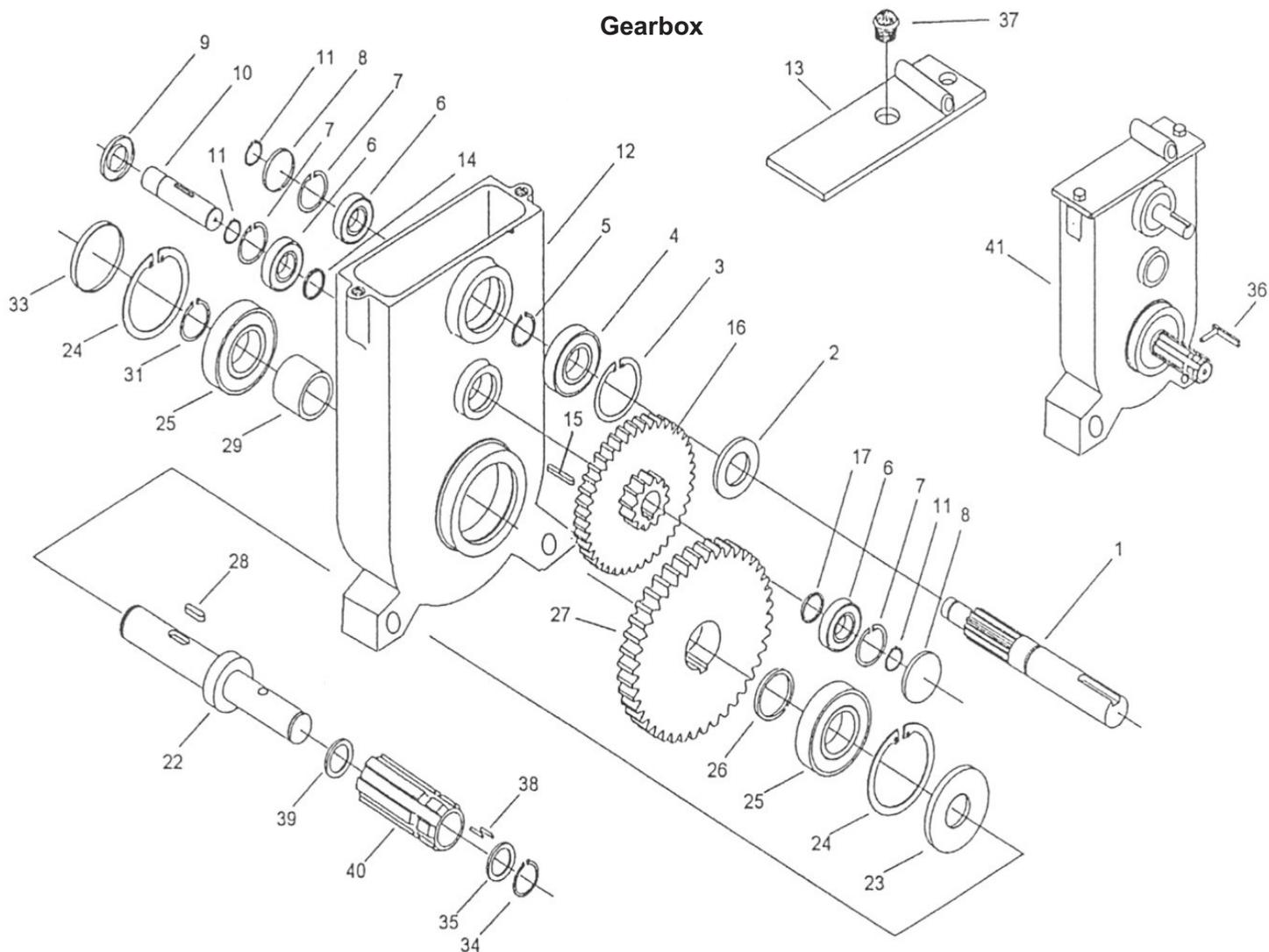

<b>Gearbox</b>			
<b>No.</b>	<b>Part Number</b>	<b>Description</b>	<b>Qty.</b>
1	022-0164-2	Shaft, (Pin Z 12M x 1.5)	1
2	022-0165-0	Oil Retainer Dia. 20 x 47 x 7	1
3	022-0166-0	Stop Ring 147	1
4	022-0167-0	Bearing 6204 2RS	1
5	022-0168-0	Stop Ring E20	3
6	022-0169-0	Bearing , 6201	3
7	022-0170-0	Stop Ring 132	2
8	022-0171-0	Plug, Dia. 132	1
9	022-0172-0	Oil Retainer Dia. 12 x 32	1
10	022-0173-0	Shaft	1
11	022-0174-0	Stop Ring E12	3
12	022-0196-1	Gearbox Body	1
13	022-0197-1	Gearbox Cover	1
14	022-0175-0	Shim, i12 x .5	1
15	022-0176-0	Key 4 x 10	1
16	022-0177-2	DOUBLE PINION Z12 M2/Z80 M1.5	1
17	022-0178-0	Shim i12 x 1	1

## Gearbox

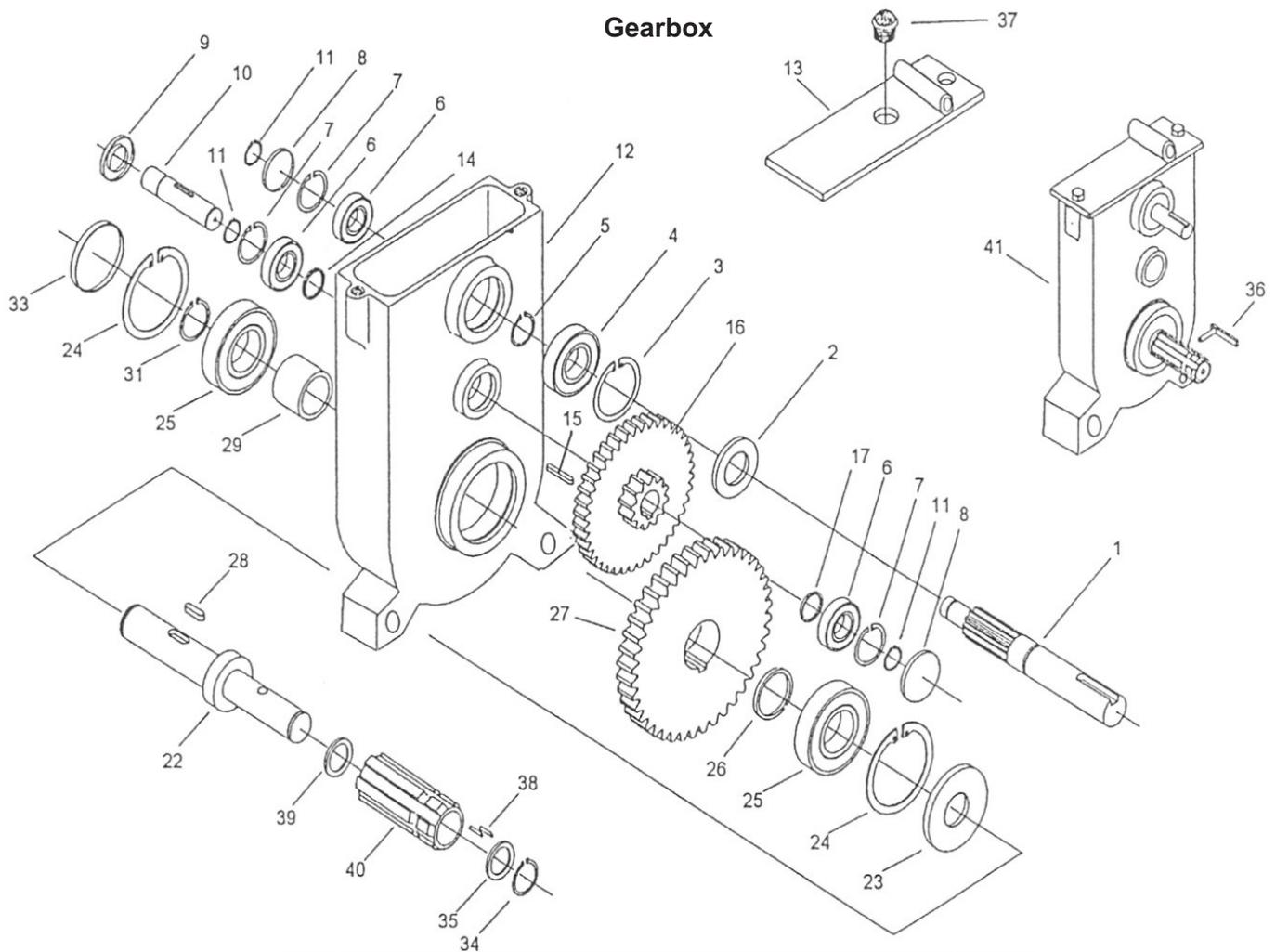

22A	022-0179-0	Output Shaft	1	
22B	022-1026-0	Shaft Assembly Complete	1	
23	022-0180-0	Oil Retainer Dia. 35 x 62 x 7 mm	1	
24	022-0181-0	Stop Ring i62	2	
25	022-0182-0	Bearing 6206 ( no seals )	2	
26	022-0183-0	Shim i 30 x .5	1	
27	022-0184-2	Pinion Z72 M2	1	
28	022-0185-0	Key, 8mm x 8mm x 20mm Long	1	
29	022-0186-0	Spacer, Dia. 33 x 42 x 19.5 TH 19.5	1	
31	022-0187-0	Stop Ring E30	1	
33	022-0188-0	Plug Dia. 62	1	
34	022-0189-0	Stop Ring E18	1	
35	022-0190-0	Spacer Dia. 18 x 2.8	1	
36	022-0191-0	Safety Key & Threaded Pin	1	
37	022-0641-0	Breather	1	
38	022-0193-0	Bearing Pins Dia. 2 x 17.8	62	
39	022-0194-0	Spacer i22 x 2.8	1	
40	022-0195-0	Splined Pin	1	
41	022-0439-3	Gearbox 40.0 to 1 Complete	1	
**	41	022-0800-0	GEARBOX,2 SPEED 27/53	1
	42	022-0121-0	Shield, PTO Cover (Not Shown)	1
	43	022-0479-0	PTO Rewind Crank (Not Shown)	1

### Drive Train Group

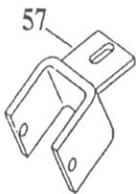
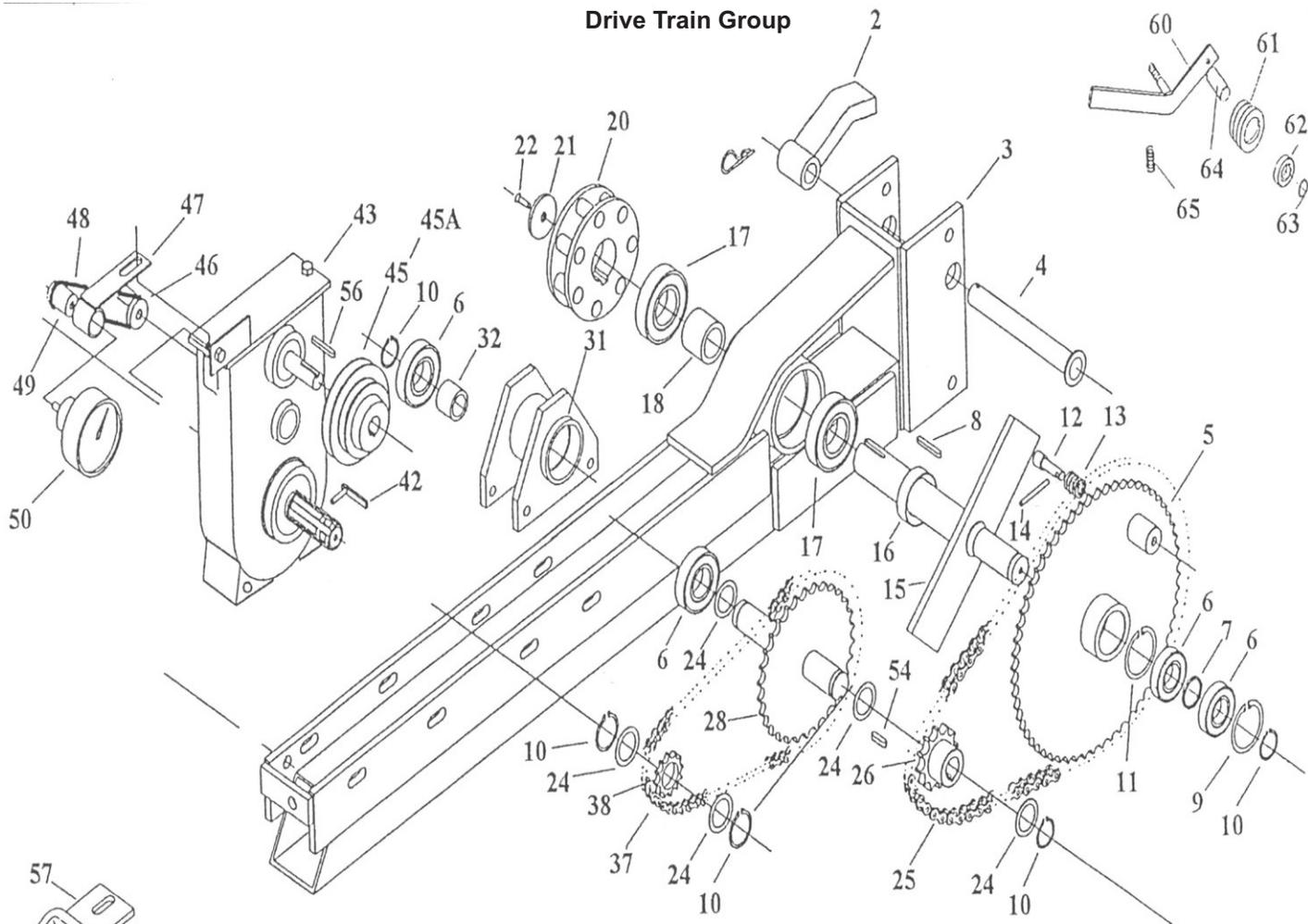

Drive Train Group				
No.	Part Number	Description		Qty.
2	022-0521-1	Anti-reverse Key (FF1)		1
3	022-0508-1	Support, FF1		1
4	022-0520-1	Pin, Anti-reverse Key		1
5	022-0496-0	Sprocket 3/4 Z60 (Double)		1
6	022-0353-0	Bearing 6207		2
7	022-0500-0	Spacer, 35		1
8	022-0499-0	Key, 16 x 40		1
9	022-0494-0	Stop Ring i72		2
10	022-0534-0	Stop Ring E35		5
11	022-0494-0	Stop Ring i72		2
12	022-0349-0	Pin		1
13	022-0347-0	Spring		1
14	022-0348-0	Pin		1
15	022-0459-1	Shaft, Dia 40mm(FF1)8.8"LONG40mm End		1
15a		<b>If this shaft has a Brake Drum on it refer to part book 350000</b>		
16	022-1468-0	Spacer, E.48 1.40,5 SP.13		1
17	022-0462-0	Bearing, 6208 2RS 40mm		2
18	022-0502-1	Spacer		1
20	022-0505-1	Pinion, 18z7		1

### Drive Train Group

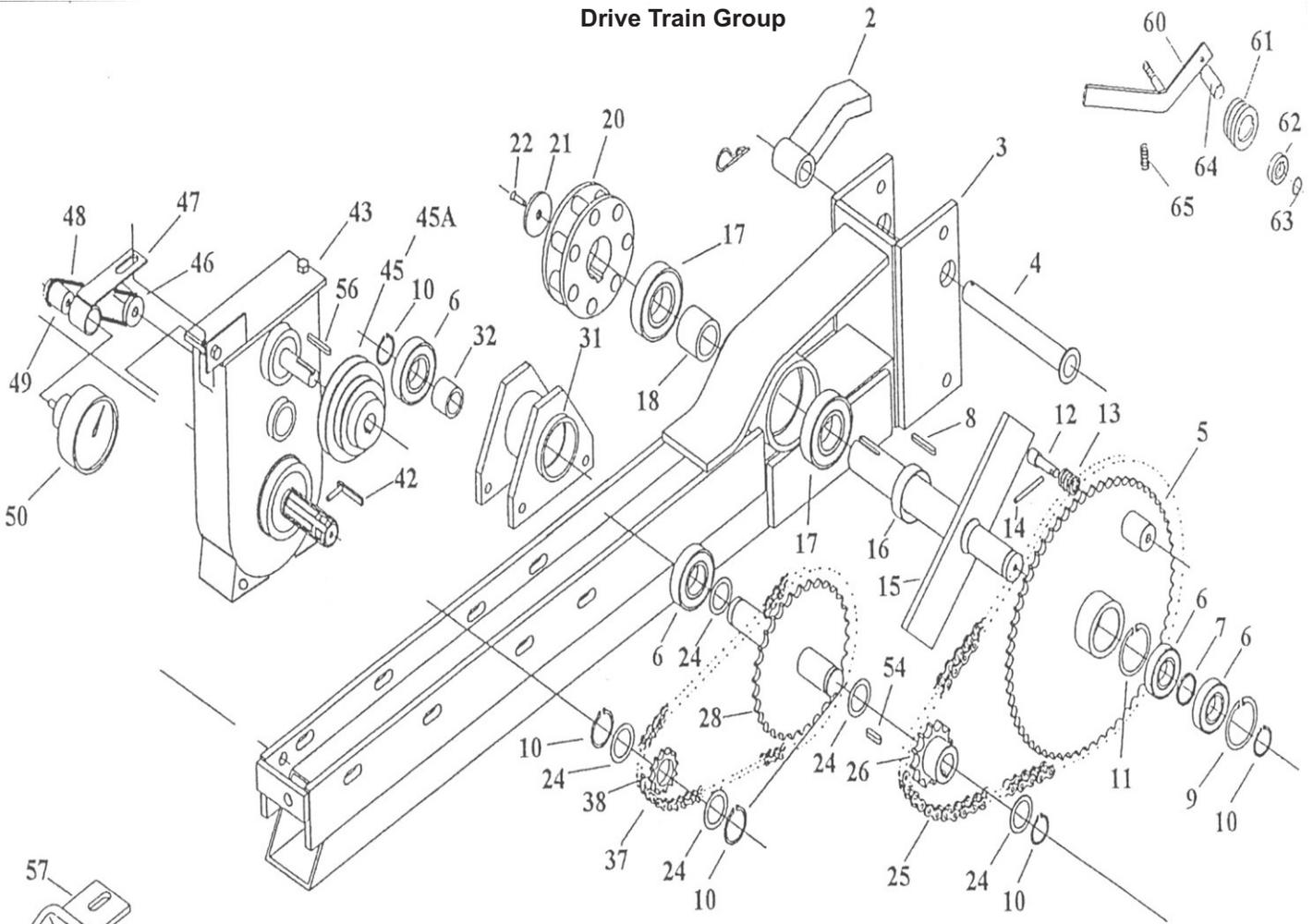

21	022-0506-0	Washer, Special		1
22	550-7011-0	Screw, 10mm x 25mm Allen Flat		1
24	022-0507-0	Shim 35 x 1		1
24A	022-0510-0	Shim, 35 x .5		1
25	875-4847-3	Chain, #3/4Double Bulk Per Foot) 77 Rollers + Conn	Ft.	4.8
26	022-0511-0	Sprocket, 3/4" Double x 13 Teeth		1
28	022-0509-0	SPROCKET 5/8"Z52 003591		1
31	022-0503-0	Support		1
32	022-0683-0	Spacer, 35 th 74		1
37	020-0114-1	Chain, 5/8" 66 Pins	Ft.	3.2
38	022-0514-0	Sprocket 13 Teeth x 5/8" Chain		1
42	022-0191-0	Safety Key w/Pin		1
43a	022-0439-3	Gearbox Complete		1
43b	022-0800-0	Gearbox, <b>2 Speed</b> 27/53 ( has shifter on top)		1
45	022-0593-0	Pulley, 3 Step		1
46a	595-0482-3	Pulley, Tach .845 with 12mm Bore		1
46b	599-0416-0	Pulley, Tach .915 with .593 Bore		1
47	022-0367-0	Meter Counter Support		1
48	022-0366-1	Belt, Dia. 3.5mm X 590mm		1
49	594-0441-1	Pulley		1
50	022-0120-0	Tach		1

### Drive Train Group

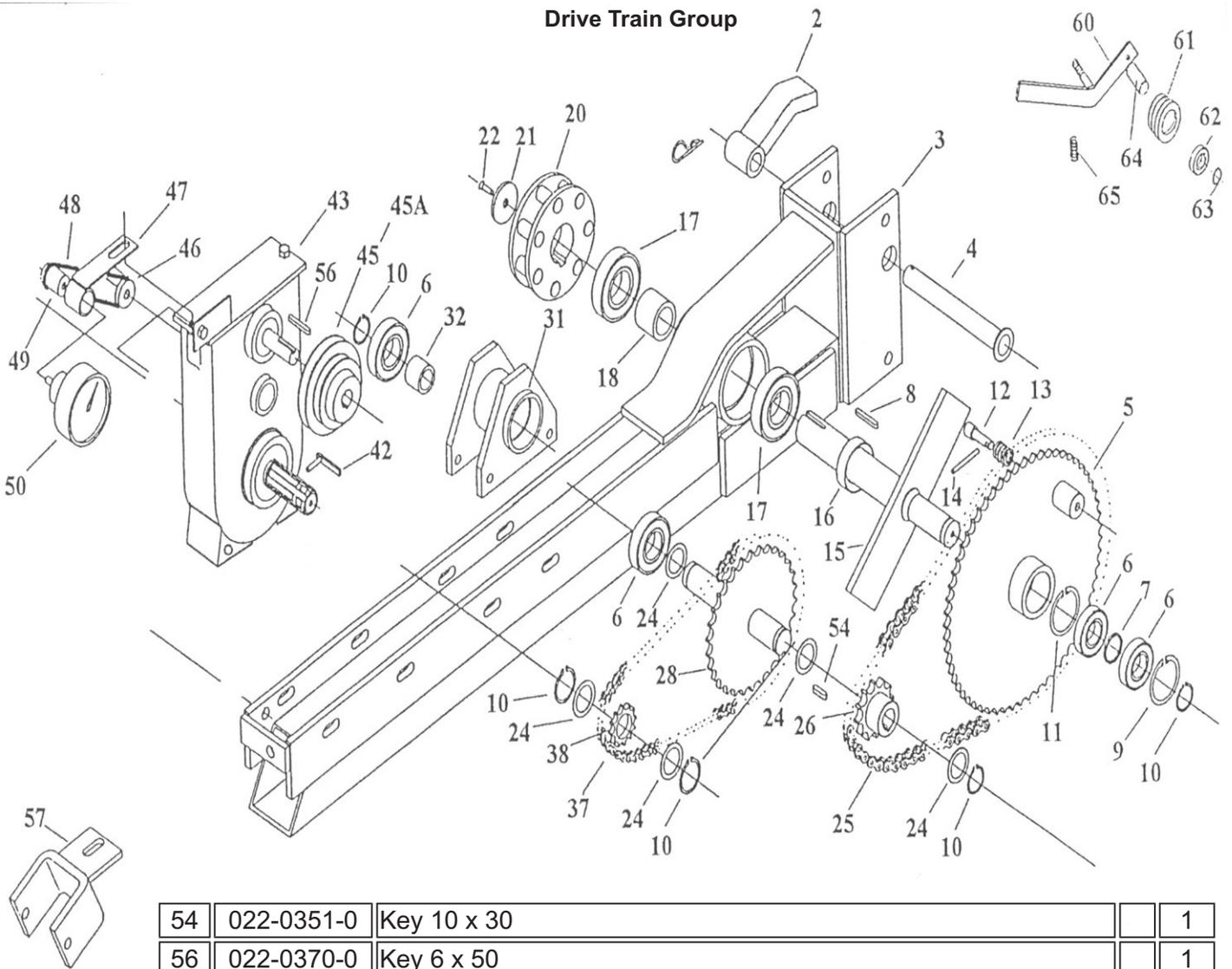

54	022-0351-0	Key 10 x 30		1
56	022-0370-0	Key 6 x 50		1
57	022-0686-0	End Support		1
60	022-0368-0	Lever, Belt Tightener		1
61	022-0654-0	Pulley, Belt Idler		1
62	022-0344-0	Bearing 6005 2RS		2
63	526-6254-0	Snap Ring		1
64	022-0653-0	Spacer, Shaft Idler		1
65	022-0318-0	Spring		1

### Sprinkler Cart Assembly

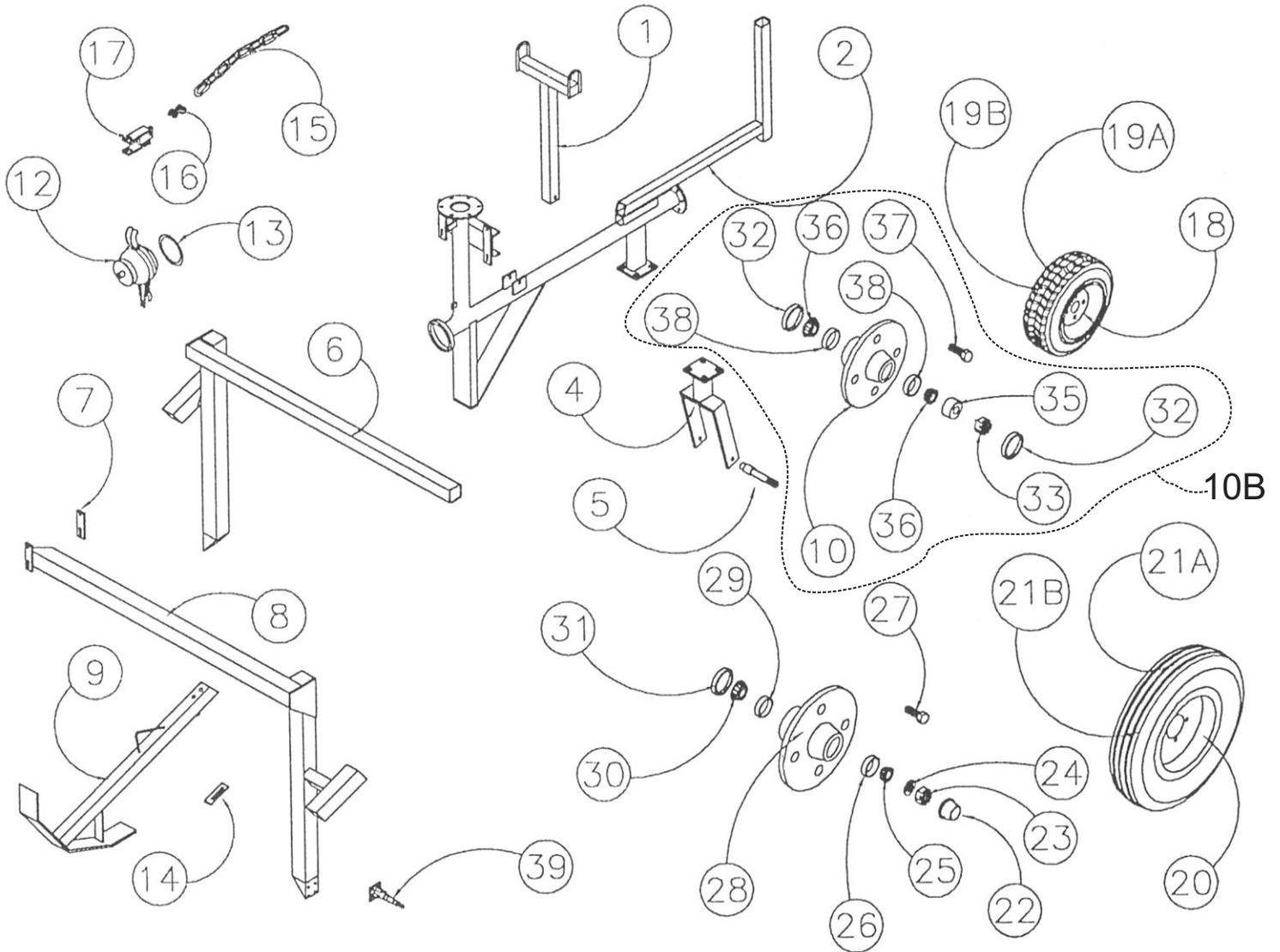

Sprinkler Cart Assembly				
No.	Part Number	Description	Qty.	
1	591-0003-1	Lift Bail	1	
2	594-0382-4	Body, Guncart	1	
4	060-0997-4	Yoke, Front Guncart	1	
56	060-1019-9	Axle, Front	1	
6	595-0492-0	Leg Inner	1	
7	584-0843-0	Strap	2	
8	595-0491-0	Leg, Outer	2	
9	595-0048-0	Stabilizer Leg	2	
10A	588-0356-4	Hub w/ Race	1	
10B	595-0382-0	Hub & Axle Assembly (Not Shown)	1	
12	594-0610-0	Cap, Guncart	1	
13	588-0023-3	O-Ring 4"	1	
14	595-0047-0	Stop, Stabilizer Leg	2	
15	850-4060-0	Chain, 3/8" Proof Coil	FT 3	
16	523-5394-1	Clevis Double	2	

### Sprinkler Cart Assembly

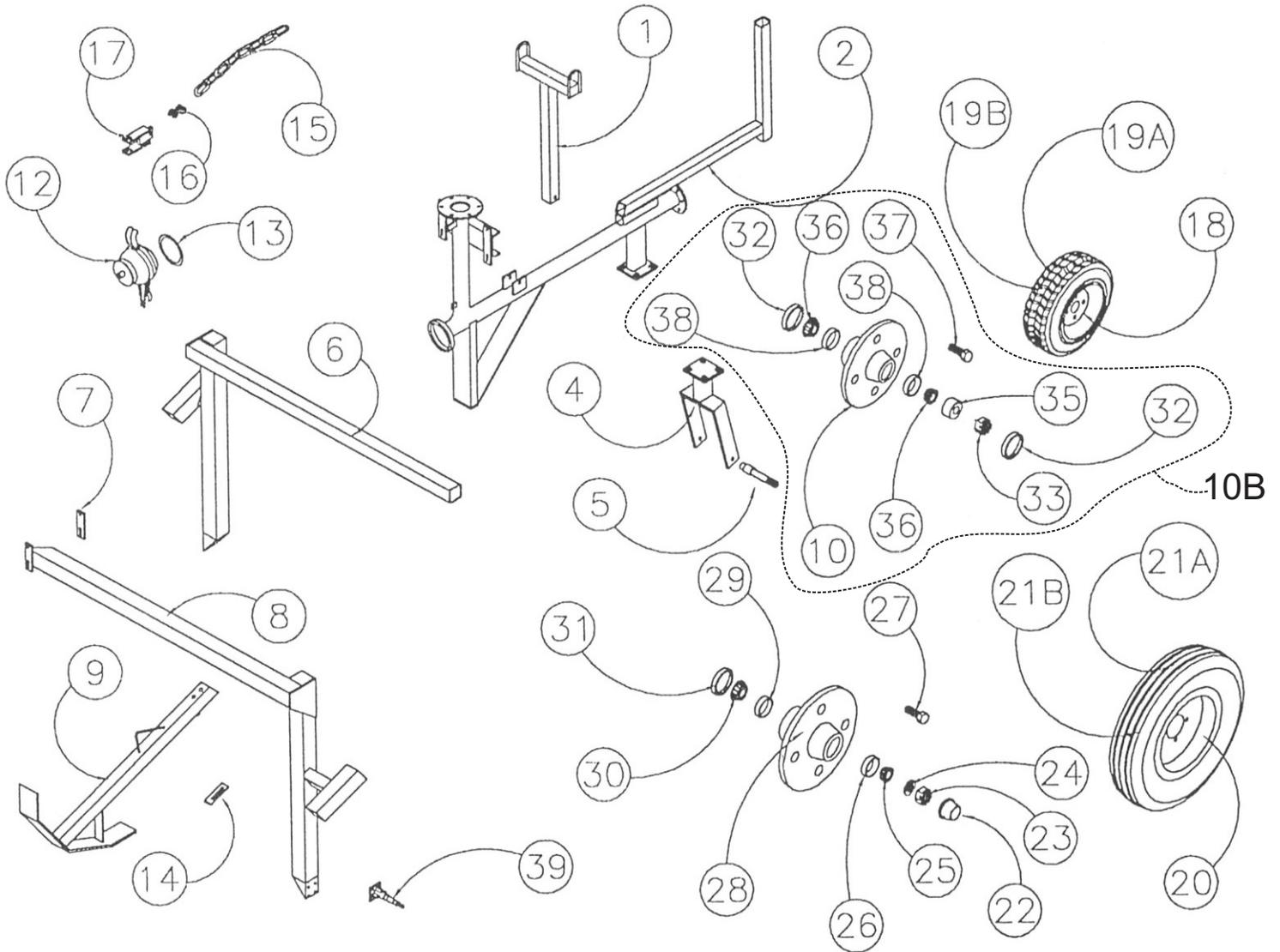

17	523-5421-0	Hitch, Chain		1
18	593-0264-0	Wheel, 8 x 5.75 4 Bolt 4" BCD		1
19A	593-0265-0	Tire, 16 x 6.5 x 8.4 PLY		1
19B	593-0265-1	Tube, Inner 16 x 6.5 x 8		1
19C	595-0606-0	Wheel & Tire Assm. Of the Above Front Wheel		1
20	502-0174-0	Wheel, 15 x 4.5 x 4 Bolt 5" BCD		2
21A	227-0256-0	Tire, 6.7 x 15 4PLY		2
21B	227-0256-1	Tube, 5.9 x 6.7 x 15		2
22	589-0062-0	Hub Cap Wilton 909911		2
23	552-0944-0	Nut, 5/8 NF Slotted		2
24	553-0943-0	Washer, 1-1/2 x 1 x 18 GA		2
25	515-0942-0	Bearing Outer LM 11949 Wilton 910260		2
26	589-0064-0	Race, Outer Wilton 910258 LM11910		2
27	589-0063-0	Bolt, Wilton 9435491		8
28	589-0065-0	Hub W/Races Wilton 280501		2
29	510-0940-0	Race Inner LM 67010		2
30	515-0939-0	Bearing, Inner LM 67010 Wilton 910259		2
31	589-0066-0	Seal CR 14975		2

### Sprinkler Cart Assembly

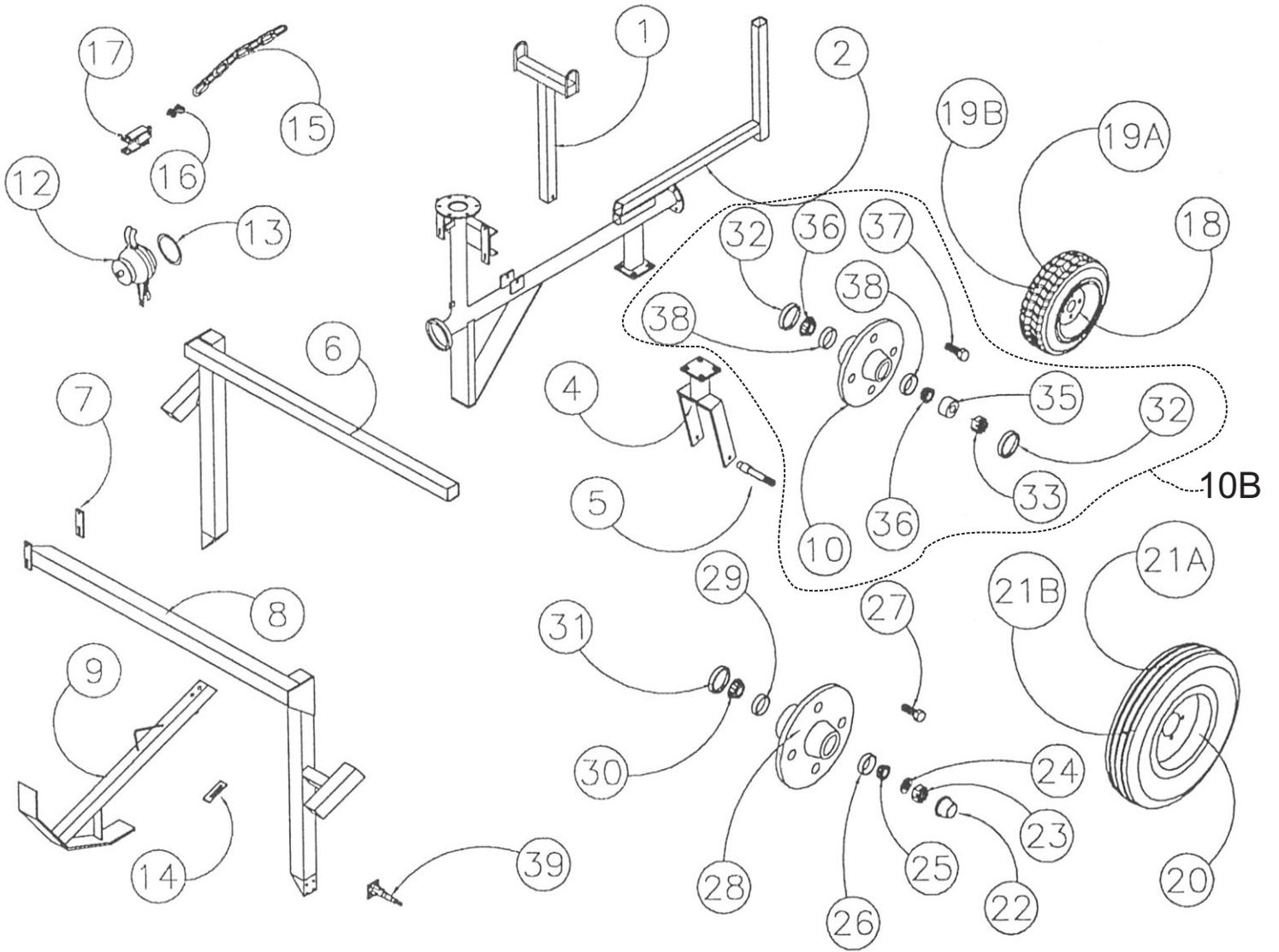

32	588-0356-5	Seal CR 12437		2
33	551-1602-0	Nut, 1" NFF Slotted		2
35	060-0245-0	Sleeve		1
36	588-0356-3	Bearing L 44643		2
37	588-0356-0	Bolt, Lug		4
38	588-0356-6	Race L 44610		2
39	595-0493-0	Spindle Rear		2

## Decals



Decals			
No.	Part Number	Description	Qty.
1	590-0013-0	Decal, Keep Slide Greased	1
2	596-0428-0	Decal, Lubrications	1
3	595-0275-2	Decal, Caution Anti-Return Pawl	1
4	596-0017-0	Decal, Caution Supply Hose	1
6	595-0276-0	Decal, Shipping Brace Only	2
7	596-0309-0	Decal, Caution Brake Adjustment	1
8	595-0275-1	Decal, Caution Locking Pin	1
9	594-0565-0	Decal, Important Sheet	1
10	590-0113-0	Decal, Gasoline	1
11	594-0565-1	Decal, Warning Sheet	1
12	585-0299-3	Decal, Logo 10"	6
14	597-0121-0	Decal, Performance Chart	1
15	596-0428-0	Decal, Lubrication (Same as Above)	1
16		Decal, Warning	1
17	596-0426-0	Decal, Service Notice	1
18	596-0427-0	Decal, Important Turn Fuel Valve	1

## Engine Drive Assembly (SN 330,000)

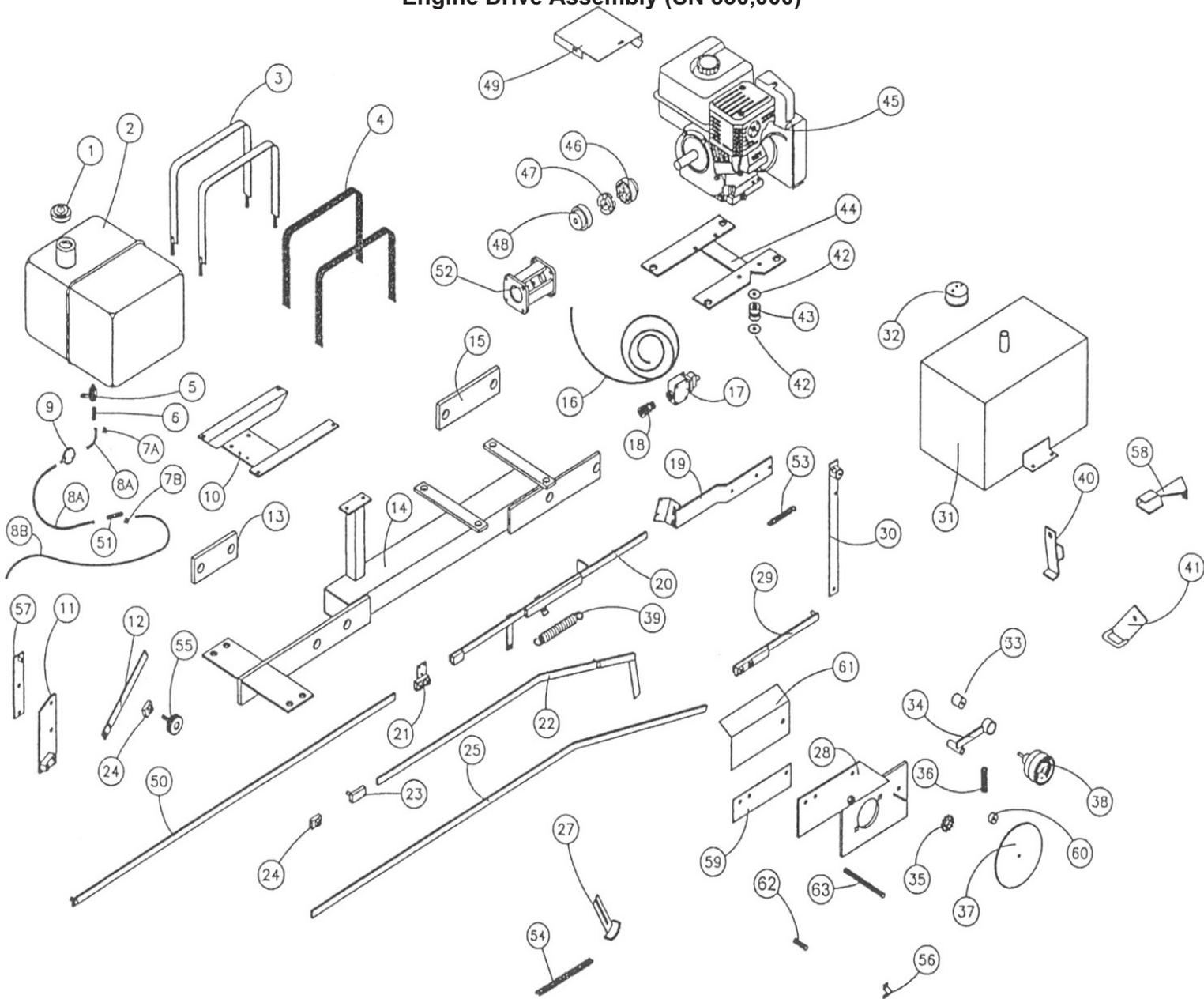

Engine Drive Assembly				
No.	Part Number	Description		Qty.
1	584-0693-9	Cap, Gas		1
2	584-0693-0	Tank, Fuel & Cap 5.3 Gal		1
3	584-0621-0	Strap, Gas Tank		2
4	587-0167-0	Belting, 1" Wide	Ft.	6
5	596-0372-0	Valve, 1/4 Turn 18"NPT Male & Female		1
6	525-4876-0	Barb, Hose 1/8" MNPT x 1/4" Hose		1
7A	060-1211-0	Clamp, Spring 1/2" OD Hose		4
7B	596-0346-0	Clamp, Spring .36 OD x .31		2
8A	584-0695-1	Hose, Gas 1/4"	Ft.	.66
8B	584-0695-0	Hose, Gas 3/16"	Ft.	1
9	596-0058-0	Filet, Gas 1/4" Flat		1
10	597-0158-0	Tank Mount, Gas		1

## Engine Drive Assembly (SN 330,000)

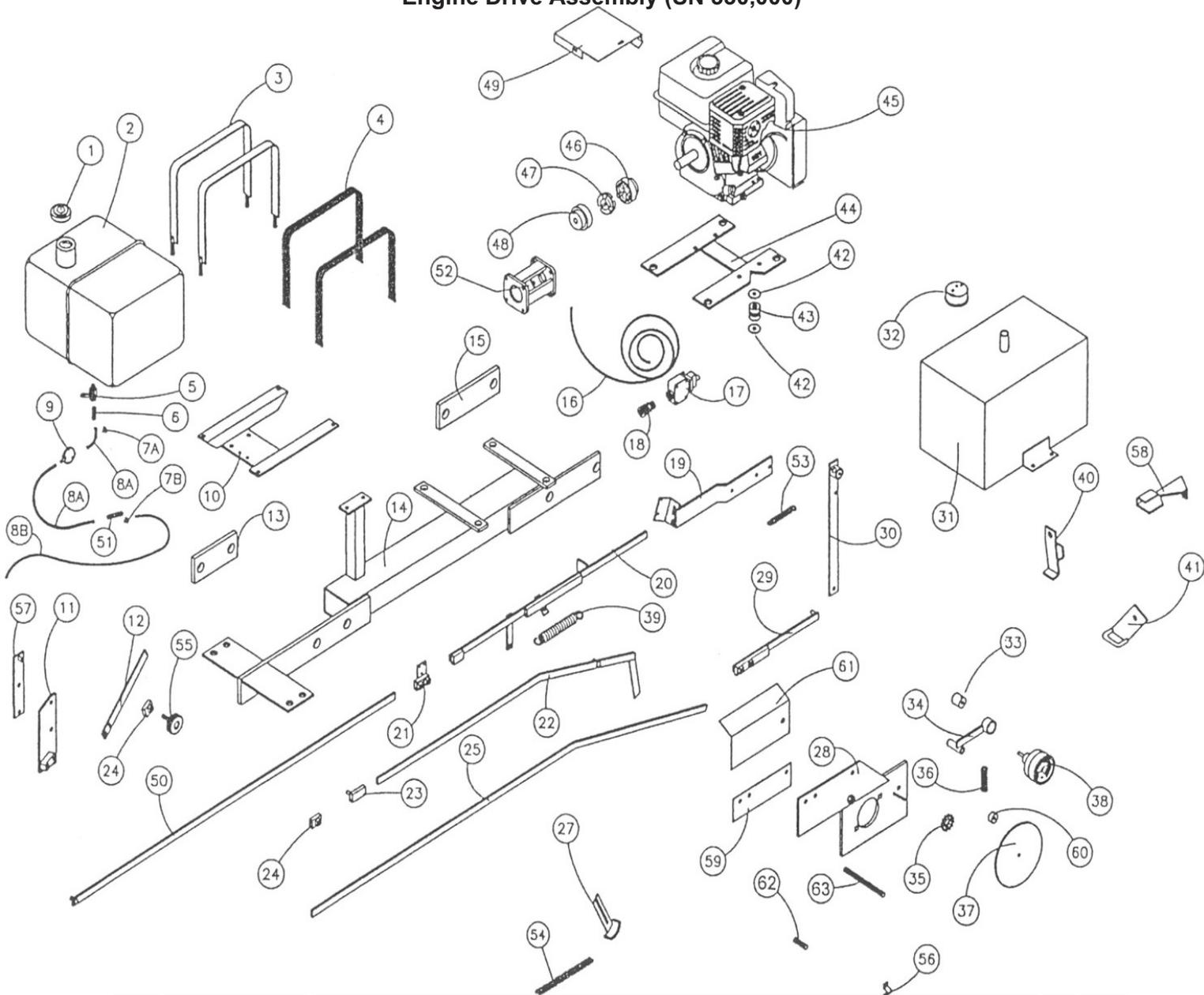

11	597-0373-0	Plate, Compensator		1
12	597-0374-0	Speed Control Arm		1
13	597-0152-0	Plate, Clamp		1
14	597-0151-1	Hyd Mt. FF1		1
15	597-0146-0	Plate, Clamp		1
16A	584-0670-0	Wire, Elect. 3 Wire 14 Ga	Ft.	15
16B	597-0327-0	Wire Adptr. (Not Shown)		1
17	526-6215-1	Switch, 6 x 613		1
18	526-6217-0	Grommet, Washer Shield		1
19	597-0187-0	Spring Holder		1
20	597-0189-0	Shut Off bar		1
21	597-0332-0	Valve Mount Tube & Stop (Used on the High Pressure Shut Down Only)		1
22	597-0188-3	Link, 37 Valve Shut Down		1
23	597-0196-0	Slide		1
24	594-0448-0	Slide		3
25	597-0376-0	Link, 37 Speed Control Rod		1

### Engine Drive Assembly (SN 330,000)

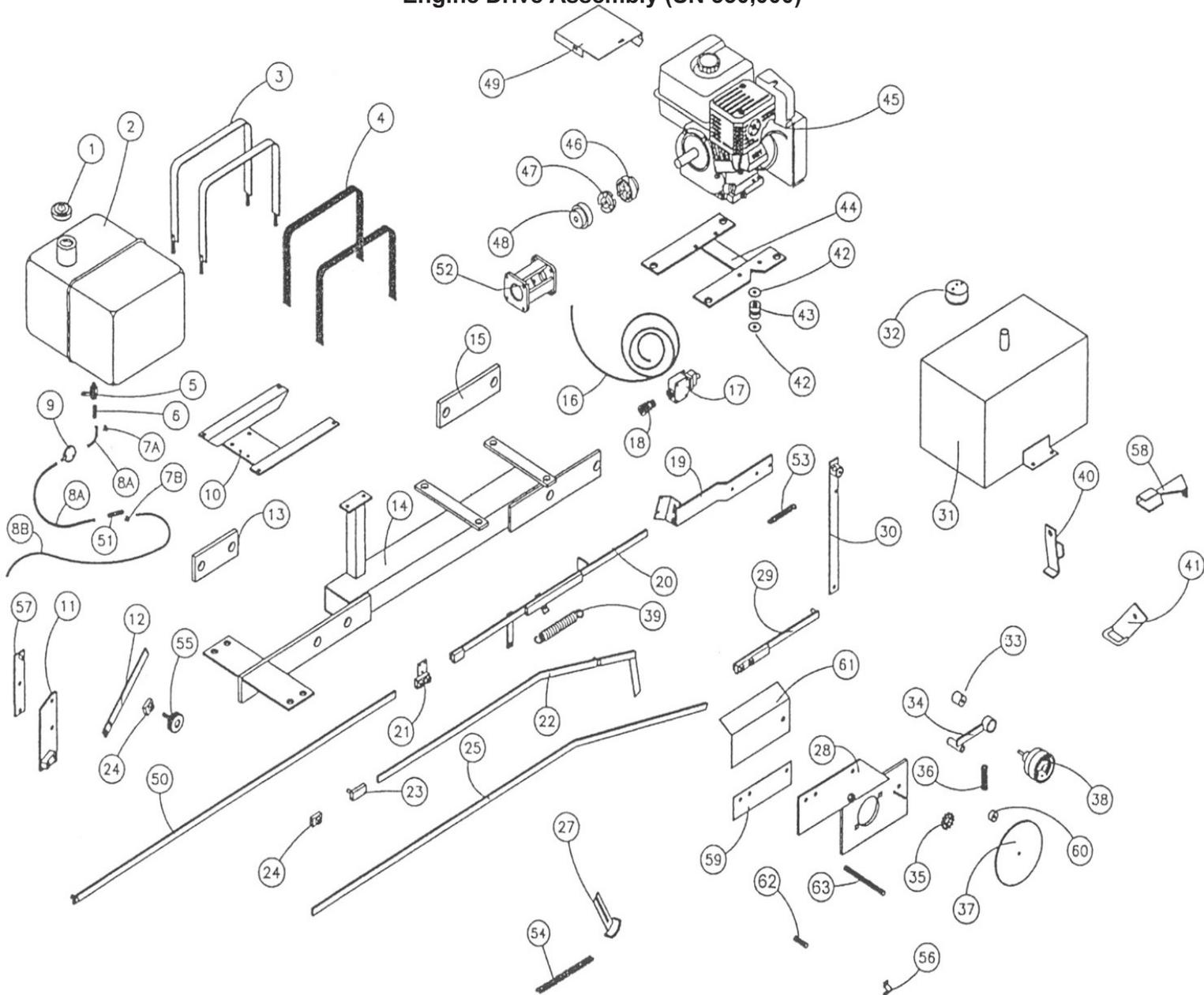

27	597-0366-0	Idler, Chain		1
28	597-0360-0	Motor Mt. Hyd. 37A		1
29	597-0375-0	Speed Adjusting Slide		1
30	597-0179-2	Arm		1
31	586-0048-1	Tank, Oil 7 Gal		1
32	595-0124-0	Cap, Oil Tank		1
33	596-0277-0	Pulley, Tach FF1 & FG1		1
34	596-0167-0	Tach Mt.		1
35	880-037-0	Sprocket, 50B12 1"Bore		1
36	593-0017-0	Spring		1
37A	596-0276-1	Tach Pulley With Tire		1
37B	596-0301-0	Tire, (Belt, 5mm x 17-1/4"		1
38	022-0120-0	Tach		1
39	450-3536-0	Spring 1 x 6 Tnsn		1
40	597-0367-0	Hose Retainer Upper		1
41	597-0193-0	Hose, Loop		1

## Engine Drive Assembly (SN 330,000)

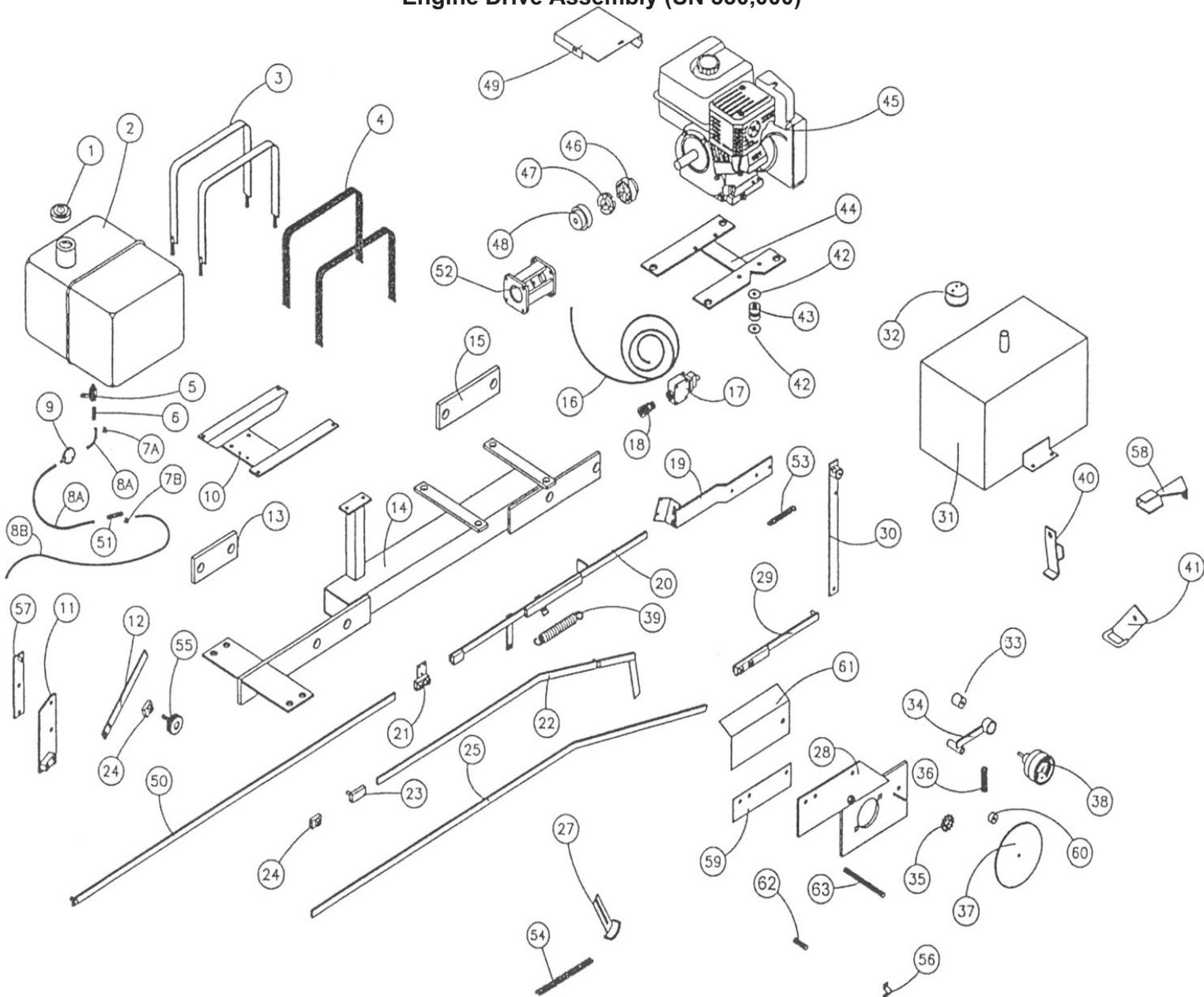

42	594-0426-1	Washer, Snubbing .09 x .4 x 1.6		8
43	594-0426-0	Dampener, Motor Mt.		4
44	594-0307-0	Mt. Honda 5.5 & 6.5 HP		1
45	584-0701-9	Engine, Honda 6.5 HP		1
46	595-0130-0	Coupling, Half Engine 3/4"		1
47	595-0103-0	Coupling, Rubber		1
48	595-0131-0	Coupling, Half Pump 1/2"		1
49	597-0166-1	Engine Cover Honda 6.5 & 5.5		1
50	597-0184-3	Link 37		1
51	592-0322-1	Barb, Rdcng. Hose 1/4" x 3/16"		1
52	595-0132-1	Adptr. Flange Engine to Pump		1
53	450-4858-2	Spring .5 OD x 2 x .47		1
54A	875-4846-0	Chain, #50	Ft.	
54B	302-0367-0	Conn. #50 (Not Shown)		1
55	526-5670-0	Knob, 3/8" x 1.0" Stud		1

# Engine Drive Assembly (SN 330,000)

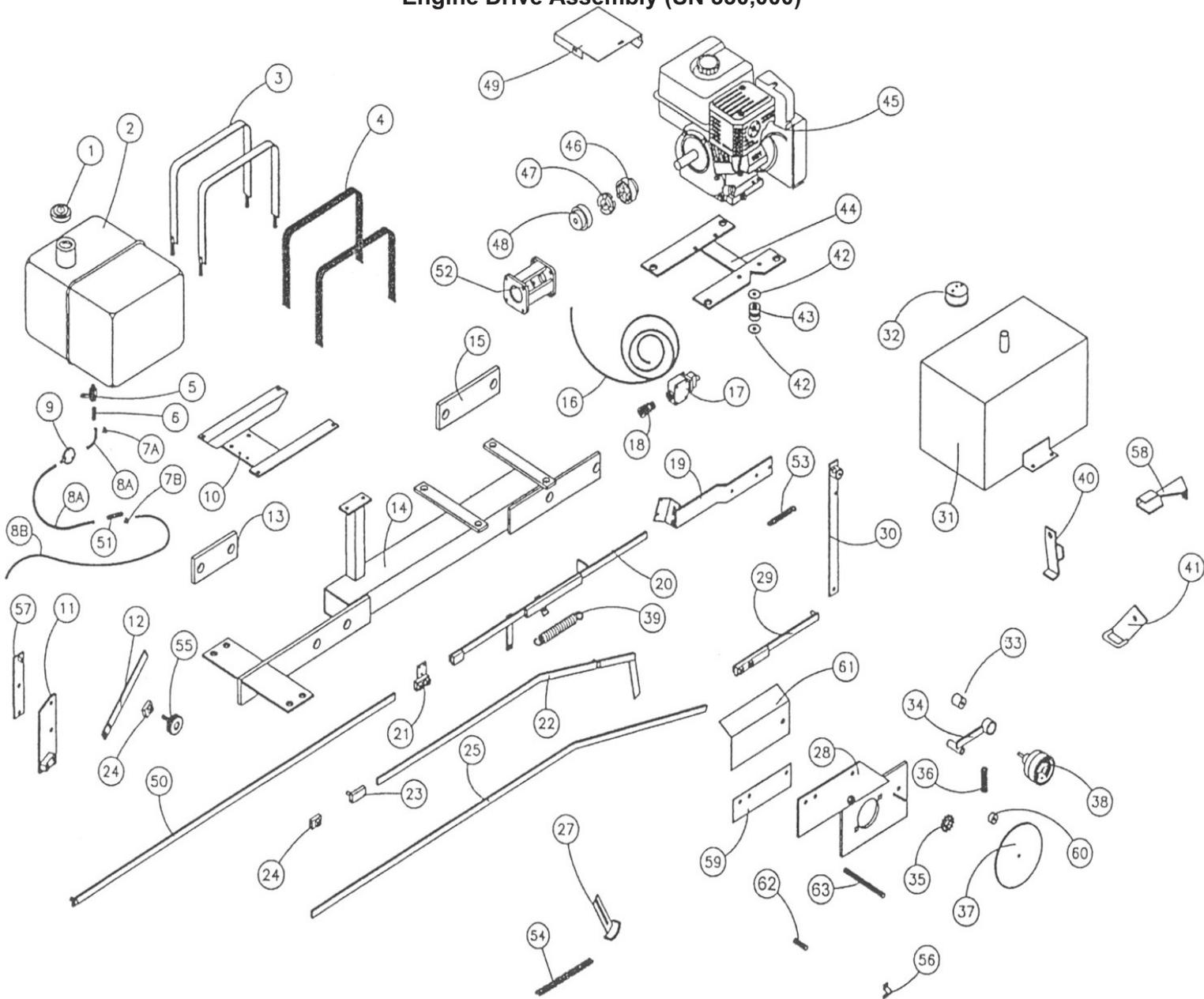

56	597-0379-0	Clamp		1
57	597-0278-0	Backing Plate		1
58	597-0370-0	Hose Retainer		1
59	597-0361-0	Shim		1
60	597-0362-0	Spacer		1
61	597-0363-0	Shield		1
62	597-0365-0	All Thread		1
63	597-0364-0	All Thread		1

## Oil Circuit Assembly

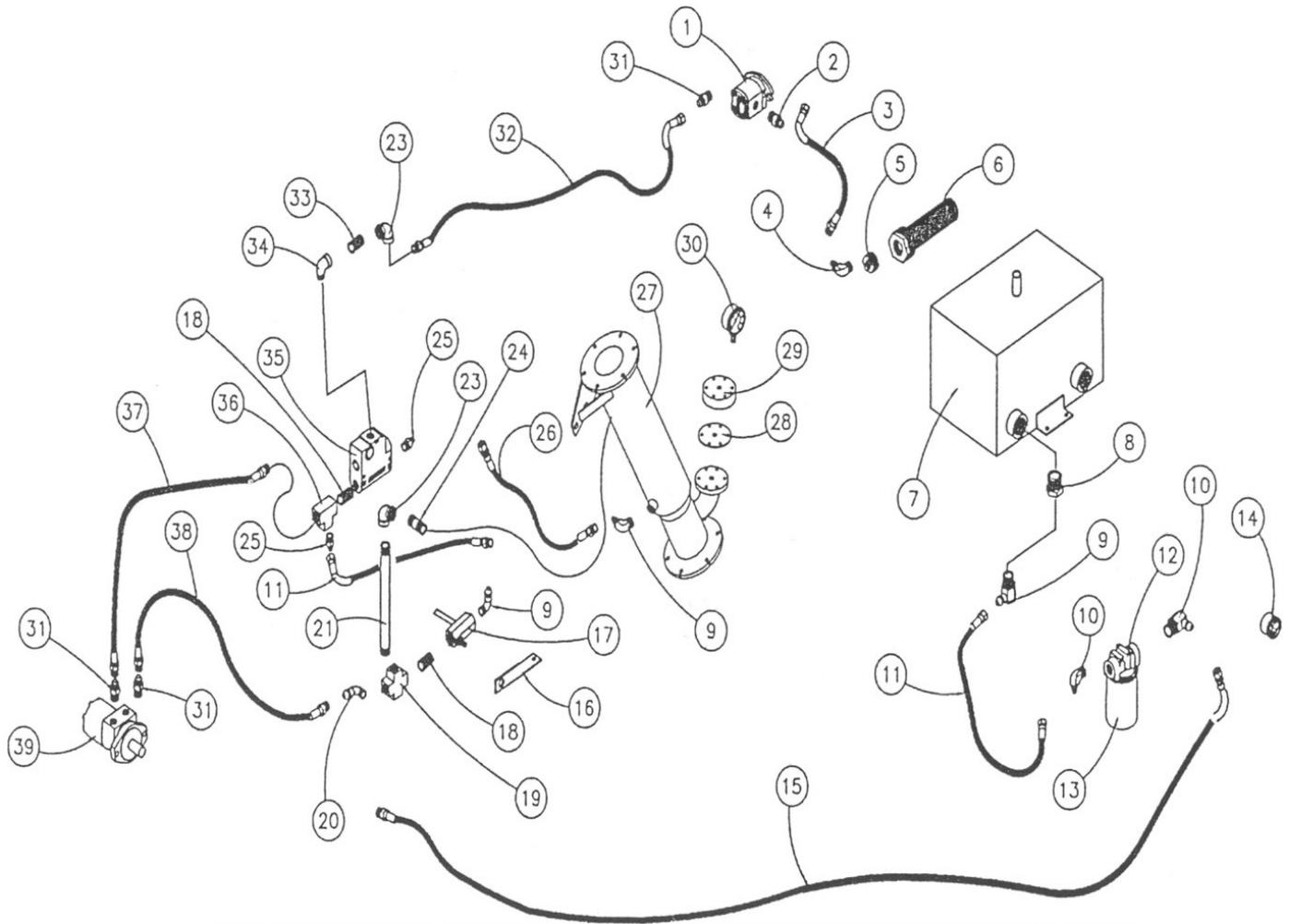

Oil Circuit Assembly			
No.	Part Number	Description	Qty.
1	595-0127-1	Pump, Hyd Barnes 10566	1
2	597-0357-0	Adptr. 10MSAE x 10MJIC	1
3	597-0301-0	Hose, 5/8" x 10FJIC 90 Deg x 10FJIC x 31.5" Long	1
4	597-0357-1	Adptr. 10MJIC x 3/4MNPT x 90Deg	1
5	525-4942-4	Bushing, Reducing 1-1/4" x 3/4" NPT	1
6	595-0080-0	Filter, Hydraulic Oil	1
7	586-0048-1	Tank, 7 Gal	1
8	525-4942-0	Bushing, Reducing 1" x 1/2" NPT	1
9	595-0122-0	Adptr. 8MJIC x 1/2"MNPT x 90 Deg	3
10	595-0204-0	Adptr. 8MJIC x 3/4"MNPT x 90 Deg	3
11	597-0298-1	Hose, 8FJIC x 8FJIC 90 Deg x 23" Long	2
12	595-0106-0	Head, Oil Filter	1
13	595-0107-0	Filter, Spin Hyd. Oil	1
14	595-0108-0	Gauge, Oil Filter	1
15	597-0382-0	Hose, .5 x 8FJIC 90 Deg x 1/2"MNPT x 121" Long	1
16	597-0378-0	Valve Stabilizer Strap	1
17	597-0295-0	Valve, 1/2" 1/4 Turn with Bolt	1
18	525-1393-4	Nipple, Close Back 1/2" NPT	2

## Oil Circuit Assembly

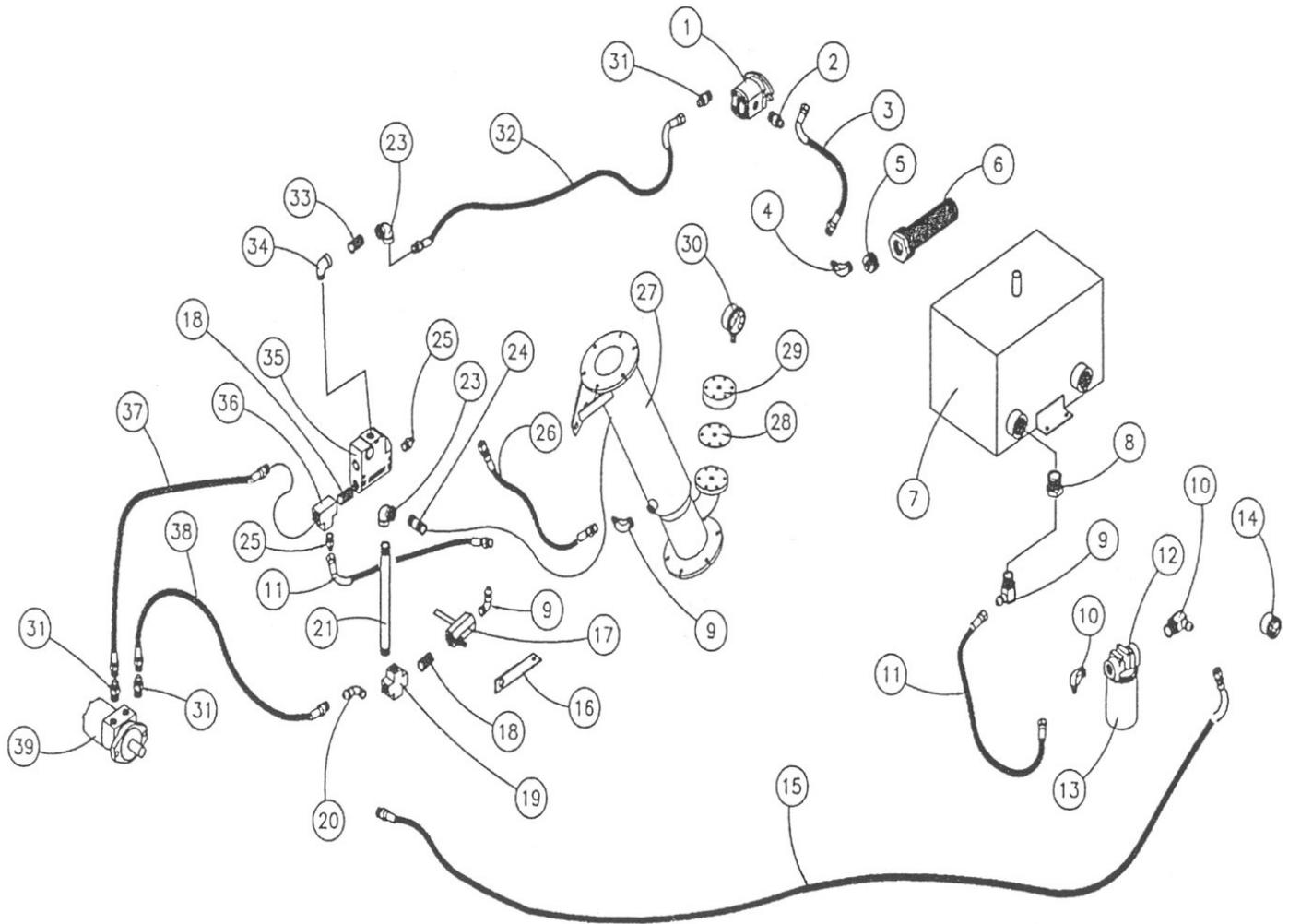

19	597-0225-0	Cross, 1/2"FNPT Hyd. Steel	1
20	595-0121-1	Adptr, 8MJIC x 1/2"MNPT x 45 Deg	1
21	525-4871-7	Nipple, 1/2"MNPT x 11" Long	1
23	525-0173-2	Elbow, 1/2" Comm Black	2
24	597-0304-1	Nipple, 1/2" x 2-1/2" Long Black	1
25	595-0121-0	Adptr, 8MJIC x 1/2"MNPT	2
26	597-0381-0	Hose, .5 x 8FJIC x 8FJIC x 19" Long	1
27	597-0175-0	Oil Cooler	1
28	587-0046-0	Diaphragm, Gauge Protector	1
29	586-0690-1	Body, Gauge Protector	1
30	586-0675-0	Gauge, Press, 0-300	1
31	595-0604-0	Adptr, 8MJC x 10MSAE	3
32	597-0303-0	Hose, .5 x 8FJIC x 1/2"MNPT x 139" Long	1
33	597-0304-0	Nipple 1/2" MNPT x 2" Long	1
34	525-1344-0	Elbow, Street BIP 1/2" x 90 Deg	1
35	595-0097-0	Flow Control 8GPM	1
36	597-0232-0	Tee, 1/2" FNPT Hyd Steel	1
37	597-0380-0	Hose, .5 x 8FJIC 90 Deg x 1/2" MNPT x 54" Long	1
38	597-0384-0	Hose, .5 x 8FJIC x 8FJIC x 46" Long	1
39	595-0098-4	Motor, Hydraulic MK12	1

## Engine Drive Assembly (SN 340,000)

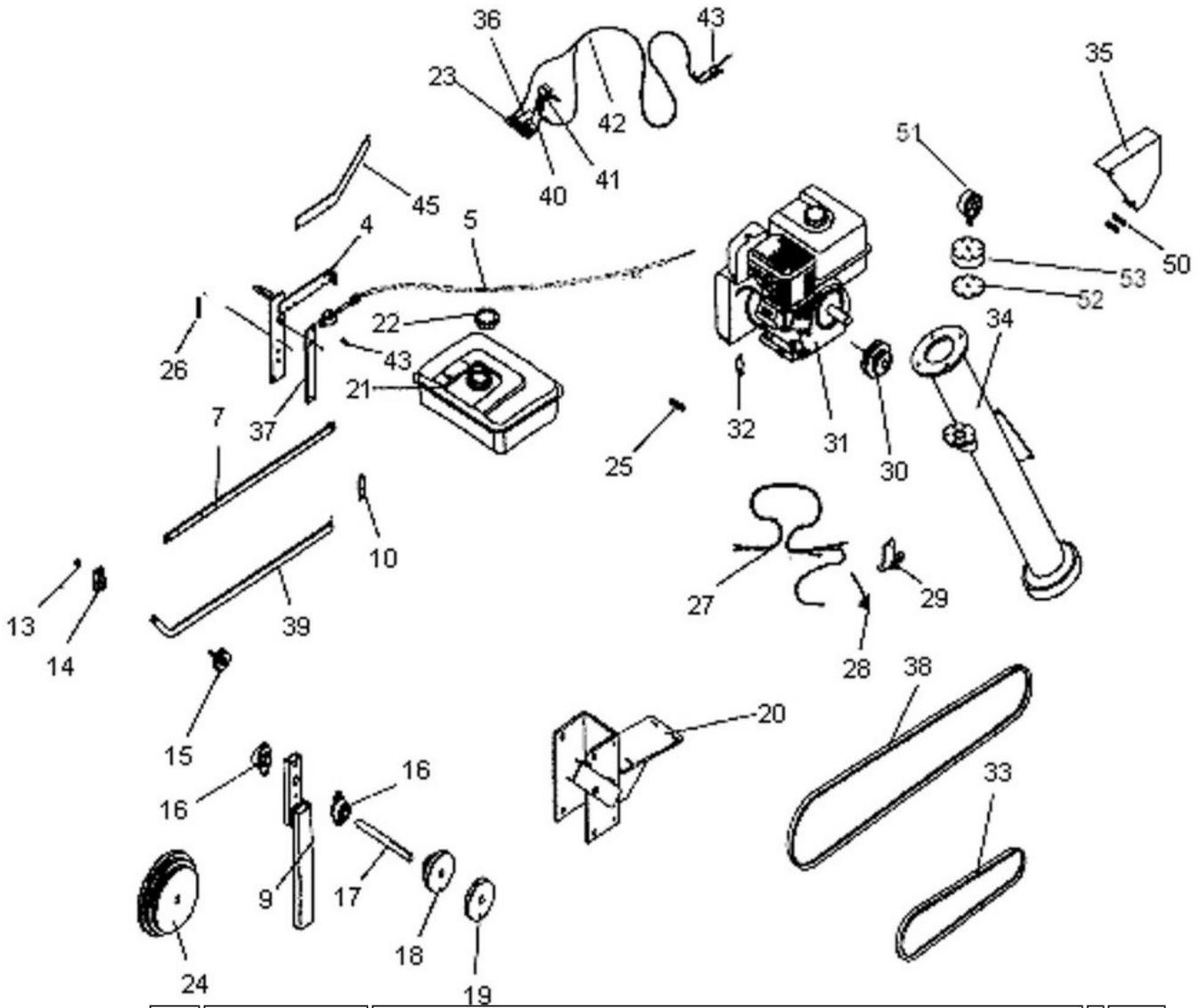

Engine Drive Assembly			
No.	Part Number	Description	Qty.
4	599-0256-0	Throttle Bracket	1
5	599-0132-0	Throttle Control Cable	1
7	599-0486-0	Throttle Rod, Comp.	1
9	599-0253-0	Jackshaft Mt.	1
10	599-0066-0	Throttle Mt.	1
13	512-4847-0	Bushing, STL .56 X .40 X .32L	1
14	599-0027-0	Swivel	1
15	526-5670-0	Knob, 3/8 x 1.0 Stud	1
16	599-0338-0	Bearing, 2 Hole 3/4B Cast Iron	1
17	599-0277-0	Jackshaft, Engine	1
18	599-0084-0	Pulley 2-3-4 .75" Bore	1
19	599-0295-0	Pulley, 4" x 3/4" Bore	1
20	599-0255-1	Mt. Engine	1
21a	599-0219-1	Fuel Tank 4 HP Robin	1
21b	599-0443-0	Fuel Tank 8 HP Honda	1

## Engine Drive Assembly (SN 340,000)

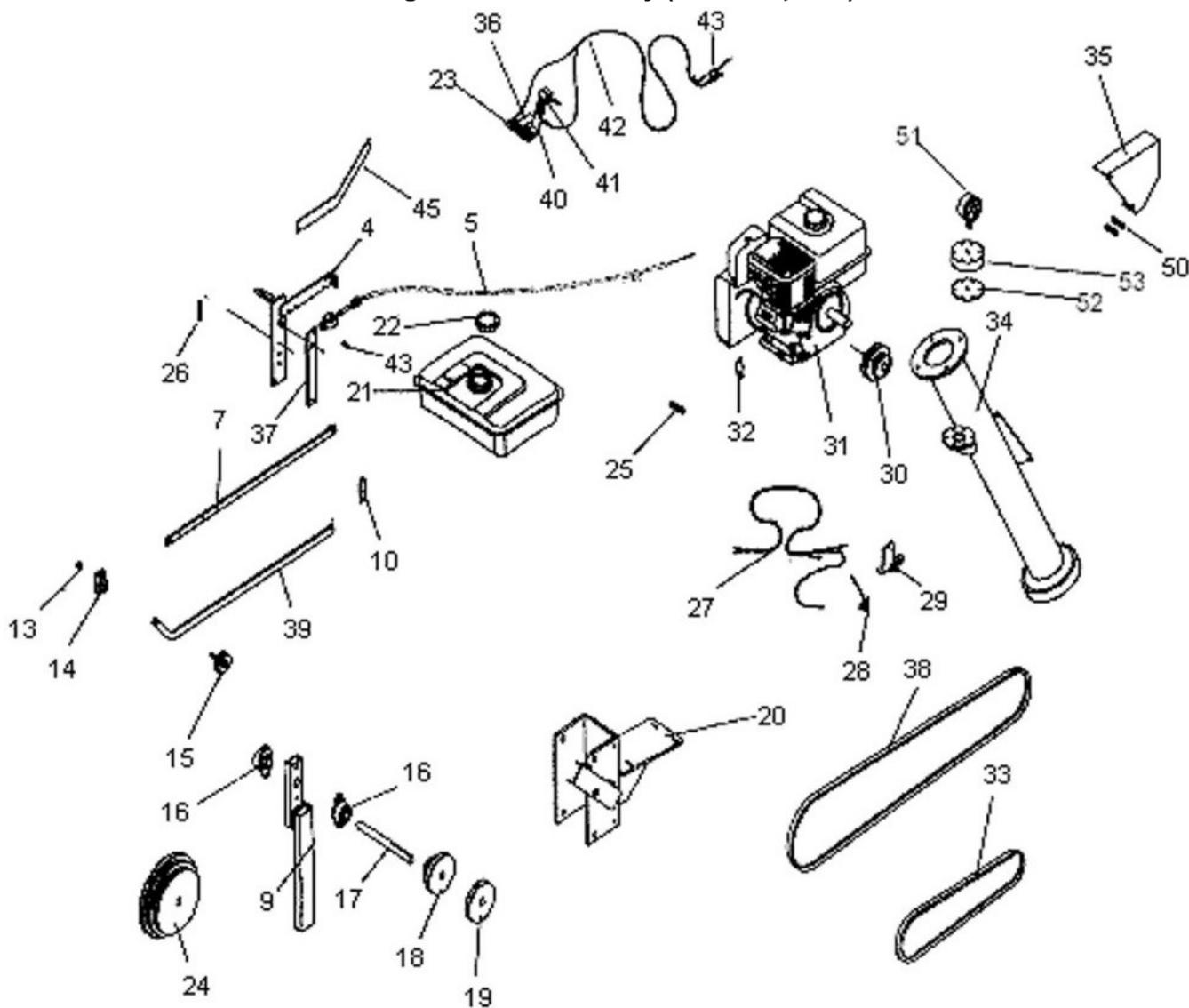

22a	599-0221-0	Cap, Robin	1
22b	599-0221-1	Cap, Honda	1
23	5990432-0	Plate	1
24	022-0593-1	Pulley, 166mm 191mm 213mm 20mm bore (on gearbox)	1
25	450-4858-2	Spring, .5 OD x 2 x .47WRL4CL	4
26	599-0422-0	Spring, .045 W x .38 x 2.5	1
27	599-0324-1	Wire Harness	1
28	599-0279-0	Switch, Robin Shut Off	1
29	599-0344-0	Switch Holder	1
30	599-0431-0	Pulley, 3.4" x .75" Bore	1
31a	598-0141-1	Engine, Robin 4 HP	1
31b	584-0701-7	Engine, Honda 4HP	1
32	599-0265-0	Spring Holder	1
33	599-0291-0	Belt, AX45	1
34	599-0268-0	Entry Fitting	1
35	599-0271-0	Shield	1
36	596-0079-0	Strap	1
37	599-0035-0	Throttle Pivot Arm	1

### Engine Drive Assembly (SN 340,000)

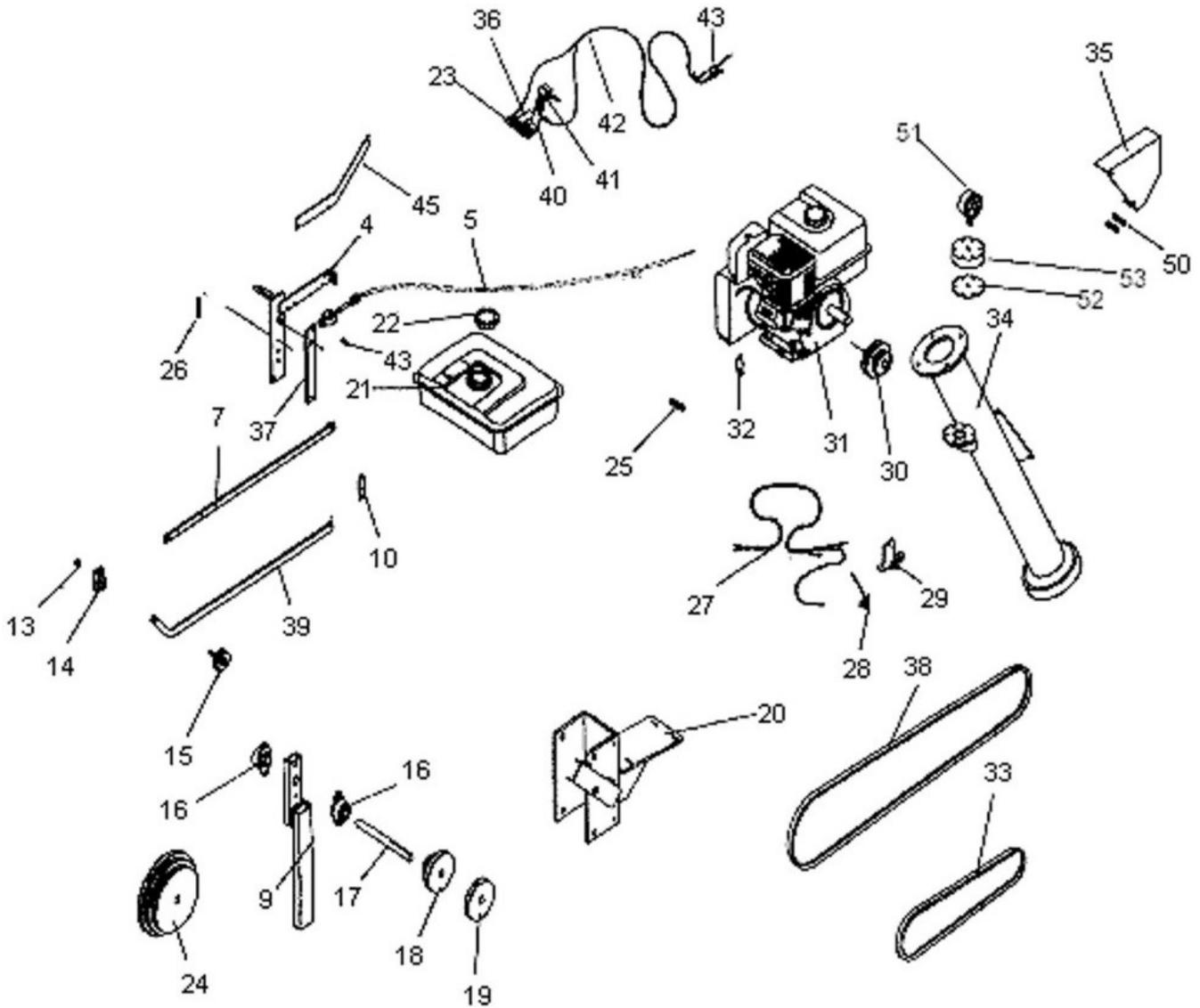

38	599-0436-0	Belt AX63		1
40	599-0424-0	Strip		1
41	599-0430-0	Switch, Contact		1
50	599-0272-0	Spring .313 OD x .049 x 3.0		1
51	586-0687-0	Gauge 300 LBS		1
52	587-0046-0	Diaphragm, Gauge Protector		1
53	586-0690-1	Body, Gauge Protector		1
54	599-0233-0	Plate (Not Shown)		1
55	599-0421-0	Shift Arm (Not Shown)		1
56	599-0278-0	Washer Plate (Not Shown)		1
1	595-0127-1	Pump, Hyd Barnes 10566		1

## Safety Shut Down

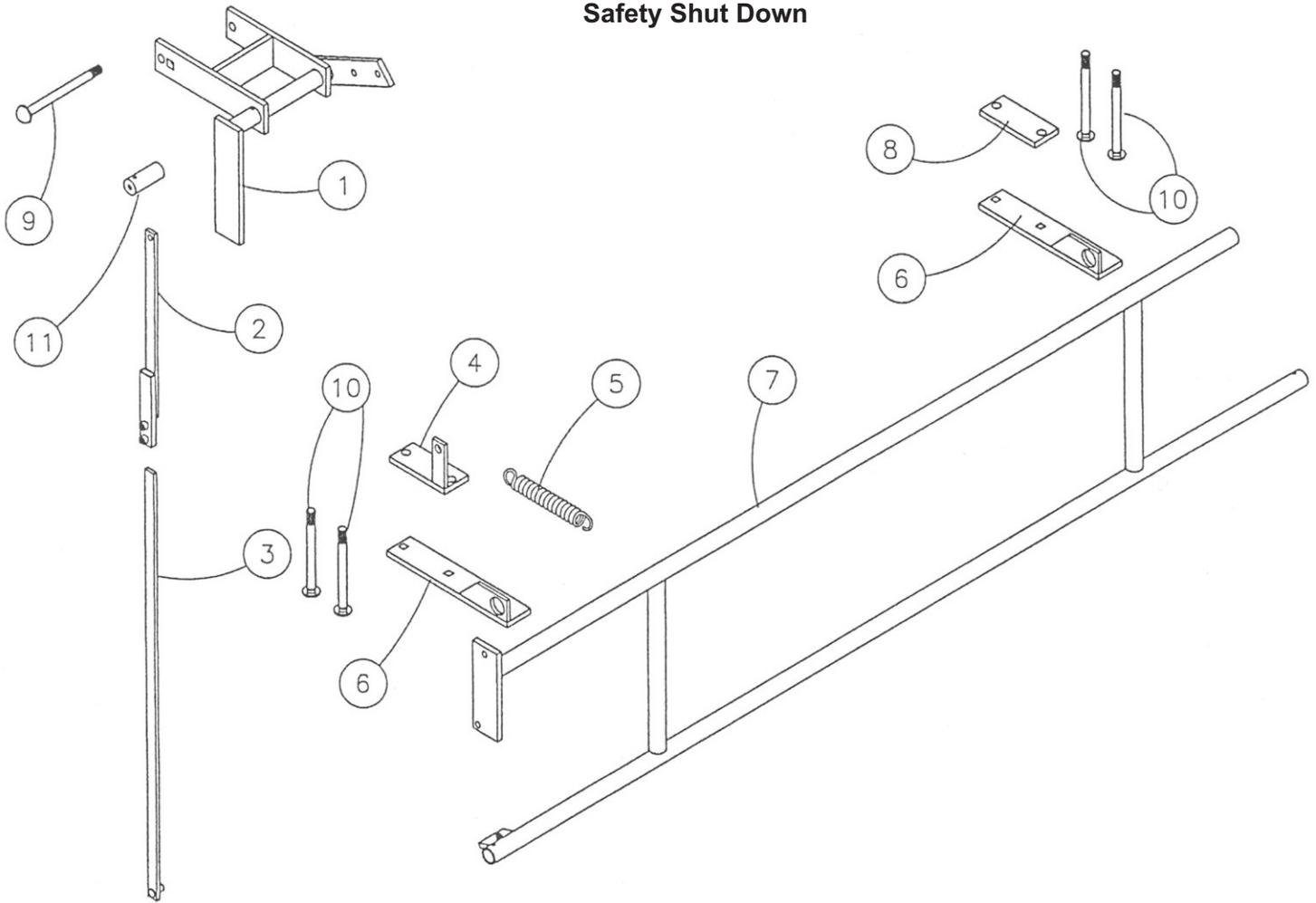

No.	Part Number	Description	Qty.
1	597-0344-1	Shut Down Arm	1
2	597-0195-0	Adjust Slide	1
3	597-0339-0	Link Shut Down	1
4	597-0348-0	Plate, Upper Clamp	1
5	450-3536-0	Spring, 1 x 6	1
6	597-0350-0	Bearing, Shut Down	1
7	597-0355-0	Safety Shut Down Bar	1
8	597-0345-0	Plate, Clamp	1
9	550-2491-1	Bolt, Carrage 1/2-13 x 4-1/2" Grd. 5	1
10	550-1229-1	Bolt, Carrage 1/2-13 x 6-1/2"	4
11	597-0105-1	Spacer, Comp 10mm	2