



Water-Reel® Irrigation

PARTS MANUAL

**Kifco AgRain S/N 400,111 +
Irrimec S/N 162 +**

ST4, ST5,ST6,ST7

FEB. 2005

700 S. Schrader Ave.
P.O. Box 290
Havana, IL 62644
USA
Phone: 309.543.4425
Fax: 309.543.4945

Notes:

For Parts That Are Described As "Left" Or "Right" The Water Inlet Side Of The Machine Is Considered The Right Side.

Items Such As Common Fasteners, Grease Fitting, And Other Small Parts Easy To Acquire Locally Are Not Listed.

Running Gear Assembly	3
Hyd. Jack	4-5
Cradle	6-9
Spool	10-14
Levelwind	15-17
Hose Retention Bar	18
Manual Lifting Device	19
Hydraulic Lifting Device	20
Automatic Lifting Device	21
Drive Train	22-24
Gearbox - TURBINE DRIVE	25-27
Engine Drive	28-30
Gearbox - ENGINE DRIVE	31-34
Turbine - 10/50	35-37
Turbine - 25/130	38-40
Gun Cart ST4	41
Gun Cart ST5 6 7	42-43

Running Gear Assembly

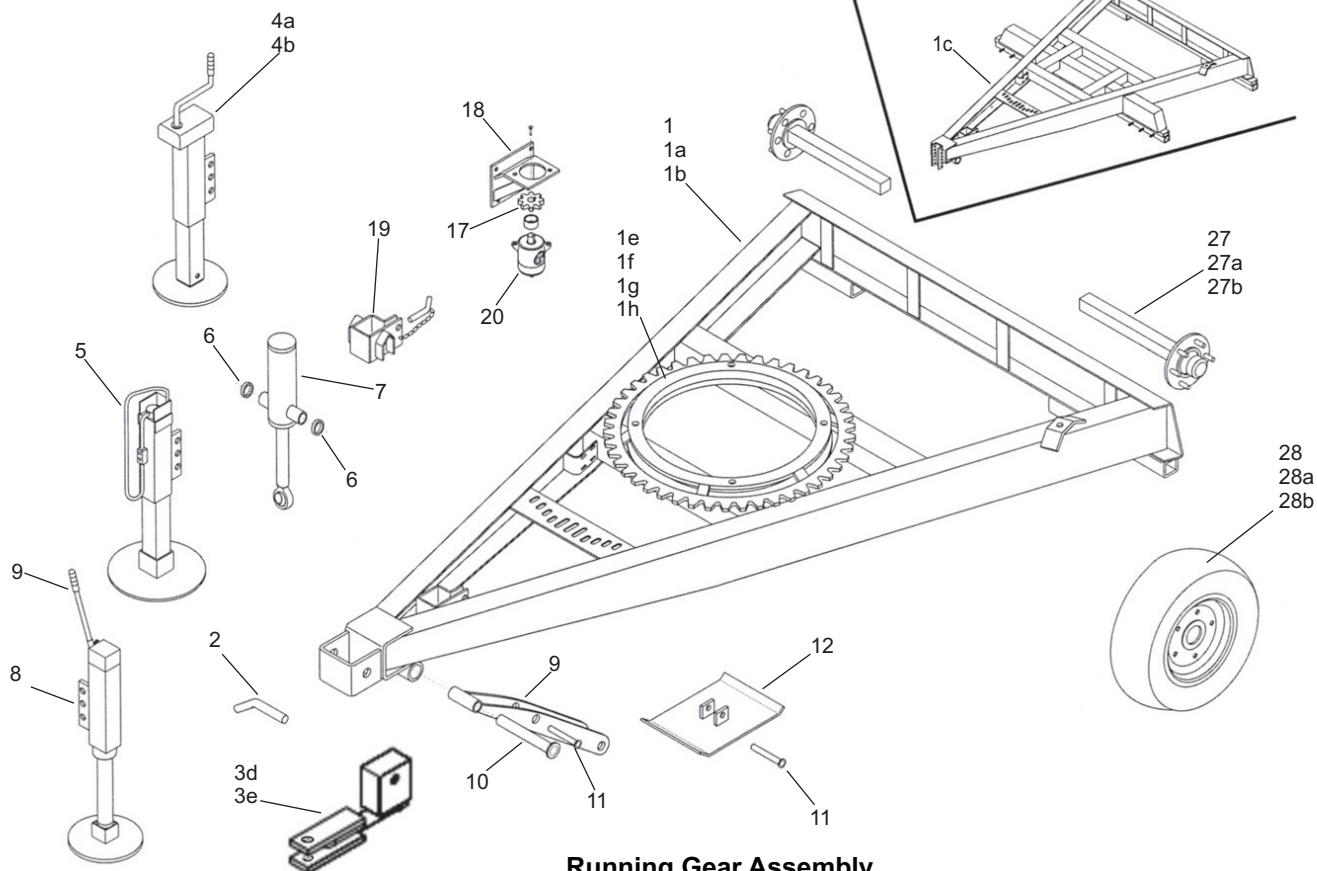

Running Gear Assembly

Item	Part Number	Description		
1	02210630	Frame AG4		1
1a	02211780	Frame AG5		1
1b	02212000	Frame AG6		1
1c	02208640	Frame AG7		1
1d	02219900	Turntable Bearing ST3		1
1e	02219901	Turntable Bearing ST4		1
1f	02219902	Turntable Bearing ST5		1
1g	02219903	Turntable Bearing ST6		1
1h	02219904	Turntable Bearing ST7		1
2	02208650	Pin		1
3d	50103822	Hitch, Clevis (AG4/5/6) Not as Shown		1
3e	58402130	Hitch, Clevis (AG7) Not as Shown		1
4a	02000402	Screwjack (AG4) Not as Shown		1
4b	02208280	Screwjack (AG5-6)		1
6	02213240	Spacer, Jack Cylinder		2
7	02208700	Cylinder, Hyd Jack - AR7/Squatter		1
8	02208670	Jack, Hand Hydraulic (AG7)		1
9	02208710	Jack Lever		1
10	02205200	Pin, Jack Arm Pivot 30MM x 225MM		1
11	02208730	Pin Dia 25MM x 115MM		2
12	02208740	Jack Base		1
17	02208770	Pinion, Turntable - A-Series		1
18	02208780	Hyd Motor Mt		1
19	02208680	Adapter, Jack, AR7		1
20	02208750	Motor		1
27	02217910	AXLE,50 X 50 X 650 AG4-5		2
27a	02217911	AXLE,60 X 60 X 750 AG6		2
27b	02217912	AXLE,60 X 60 X 800 AG7		2
28	02217920	WHEEL & TIRE 10.80/12 PR8 AG4-5		2
28a	02217921	WHEEL & 10.0/75-15.3/8 PR - 6 holes AG6, (AG7 Four wheels chassis)		2
28b	02217922	WHEEL & TIRE 11.5/80-15.3 12 PR for AG7 Two Wheel chassis		2

Hyd. Jack ST7

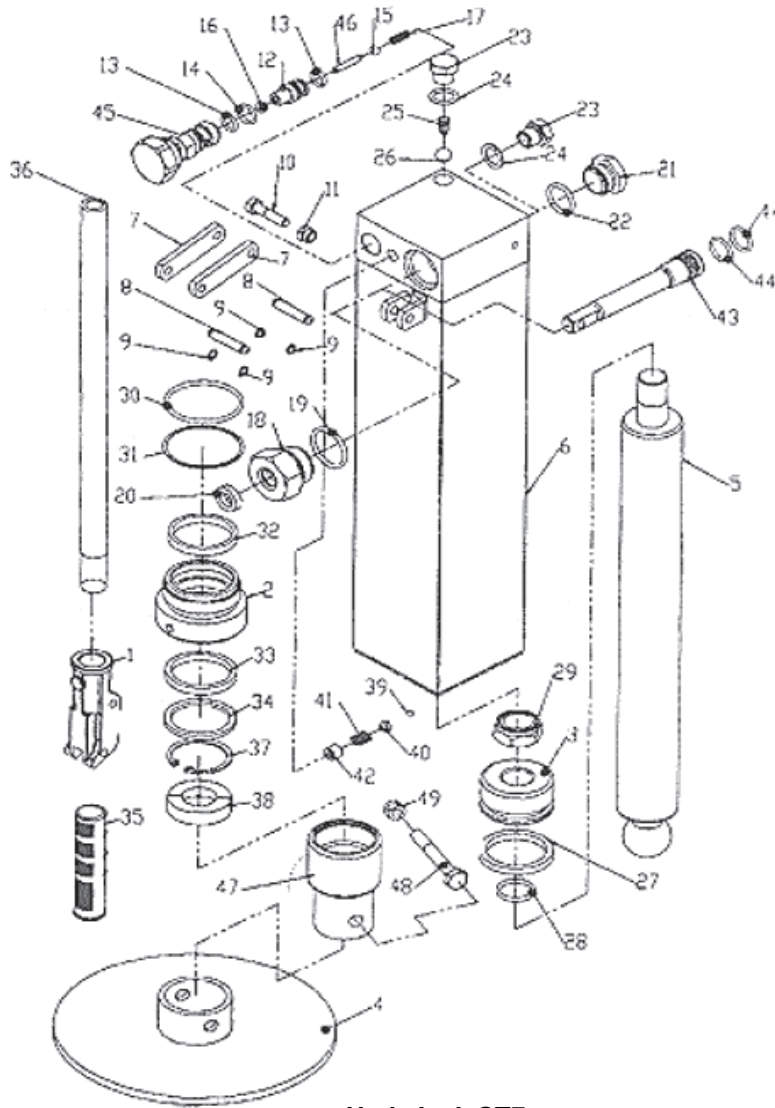

Hyd. Jack ST7

Item	Part Number	Description		
1	50401010	HANDLE,BRACKET - HYD JACK		1
2	50401020	HOUSING, LOWER - HYD JACK		1
3	50401030	HOUSING, UPPER - HYD JACK		1
4	50401040	FOOT - HYD JACK		1
5	50401050	CYLINDER JACK		1
6	50401060	JACK HOUSING HYD JACK		1
7	50401070	HANDLE STRAP, HYD JACK		2
8	50401080	HANDLE PIN, HYD JACK		2
9	50401090	SNAP RING, HYD JACK		4
10	55070220	BOLT,8-1.25MM X 35MM		1
11	50401110	NUT, 8MM		1
12	50401120	VALVE SEAT, HYD JACK		1
13	50401130	O-RING 115, HYD JACK		2
14	50401140	O-RING 121, HYD JACK		1
15	50401150	8MM BALL, HYD JACK		1
16	50401160	10MM BALL, HYD JACK		1
17	50401170	SPRING, HYD JACK		1
18	50401180	PACKING NUT, HYD JACK		1
19	50401190	O-RING 4131, HYD JACK		1
20	50401200	SEAL, HYD JACK		1
21	50401210	CAP, HYD JACK		1
22	50401220	O-RING 4093, HYD JACK		1
23	50401230	95MM PB23 UNI 4838, HYD JACK		1

Hyd. Jack ST7 (cont.)

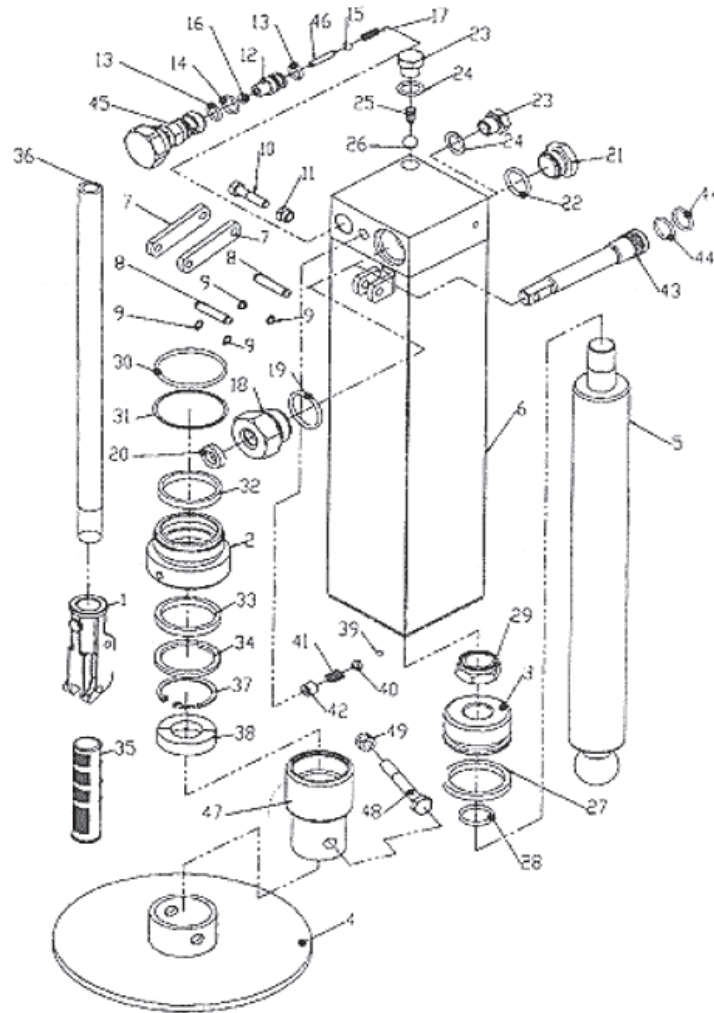

Item	Part Number	Description		1
24	50401240	RING, SEALING, HYD JACK		1
25	50401250	SPRING, HYD JACK		1
26	50401260	PLUG, (BALL) HYD JACK		1
27	50401270	SEAL, UPPER - HYD JACK		1
28	50401280	O-RING, UPPER (.14X1"ID)- HYD JACK		1
29	50401290	NUT, NYLOCK ROD TOP - HYD JACK		1
30	50401300	O-RING, LOWER (.14X2.25ID)-HYD JACK		1
31	50401310	GUARD, DUST - HYD JACK		1
32	50401320	GUARD DUST, HYD JACK		1
33	50401330	SEAL, LOWER - HYD JACK		1
34	50401340	WIPER, ROD - HYD JACK		1
35	50401350	HANDLE GRIP, HYD JACK		1
36	50401360	HANDLE, HYD JACK		1
37	02215440	SNAP RING, MAN/HYDRAULIC JACK, A-SE		1
38	50401380	SPACER, HYD JACK		1
39	50401390	BALL, 5.5MM, HYD JACK		1
40	50401400	SEAT, HYD JACK		1
41	50401410	SPRING, HYD JACK		1
42	50401420	SPACER, HYD JACK		11
43	50401430	PISTON, HYD JACK		1
44	50401440	O-RING 3081, HYD JACK		1
45	50401450	VALVE, HYD JACK		1
46	50401460	PIN, HYD JACK		1
47	50401470	KNUCKLE, FOOT TO ROD - MAN/HYD JACK		1
48	55070021	BOLT, 10-1.5MM X 75MM ZINC PLATED		1
49	55170010	NUT 10-1.5MM		1

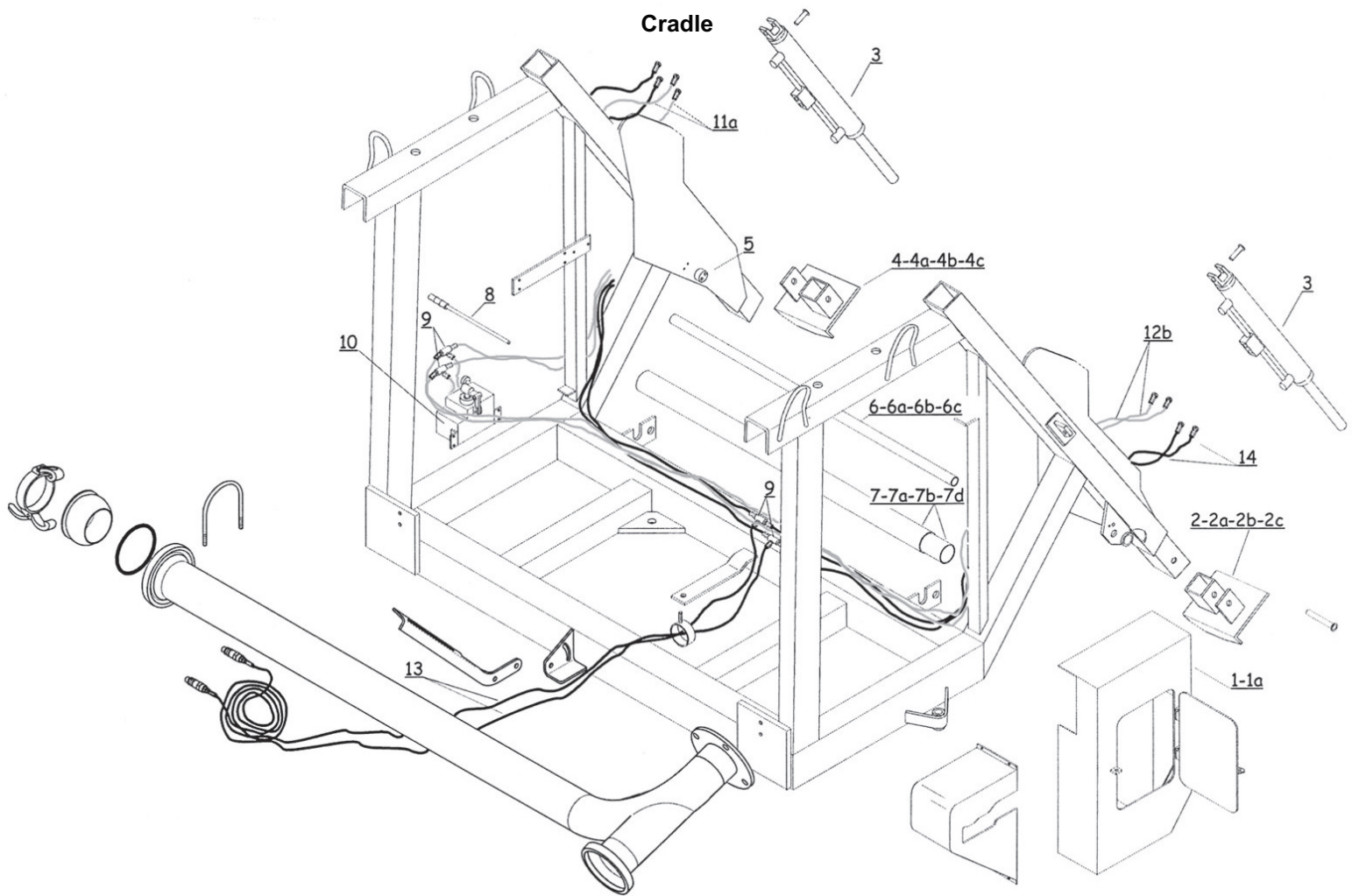

Item	Part Number	Description		
1	02210670	GUARD, CABINET - A-SERIES		1
1a	02210671	GUARD, PLASTIC PTO - AR-SERIES (not shown)		1
2	02210680	FOOT, STABILIZER-TURBINE SIDE -AG4		1
2a	02211530	FOOT, STABILIZER -TURBINE SIDE -AG5		1
2b	02211950	FOOT, STABILIZER TURBINE SIDE -AR6		1
2c	02208820	FOOT, TURBINE SIDE STABILIZER-AR7		1
3	02212240	CYLINDER, HYD LEG - AR5/5+/6/7		2
4	02210690	FOOT, STABILIZER CHAIN SIDE -AG4		1
4a	02211540	FOOT, STABILIZER CHAIN SIDE -AG5		1
4b	02211960	FOOT, STABILIZER CHAIN SIDE -AG6		1
4c	02208840	FOOT, STABILIZER CHAIN SIDE -AG7		1
5	02218730	PAD ST6-7		1
6	02210700	HOSE GUIDE BAR AG4		1
6a	02211550	HOSE GUIDE BAR AG5		1
6b	02211970	HOSE GUIDE BAR AG6		1
6c	02208860	HOSE GUIDE BAR AG7		1
7	02210710	ROLLER, AG4		1
7a	02211560	ROLLER, AG5		1
7b	02211980	ROLLER, AG6		1
7d	02213810	ROLLER, AG7		1
8	02218740	HANDLE, JACK		1
9	02208890	TEE, HYDRAULIC 1/4" BSPP- A SERIES		2
10	02214550	HYDRAULIC.PUMP		1
11a	02208910	HOSE ASM, TEE TO CYLINDER-AR5/6/7		2
12b	02214560	HOSE, R1T X 3.4MT HYD MAN AG7		2
13	02208950	HOSE ASM, TO TRACTOR-AR5/6/7		2
14	02208910	HOSE ASM, TEE TO CYLINDER-AR5/6/7		2

Cradle

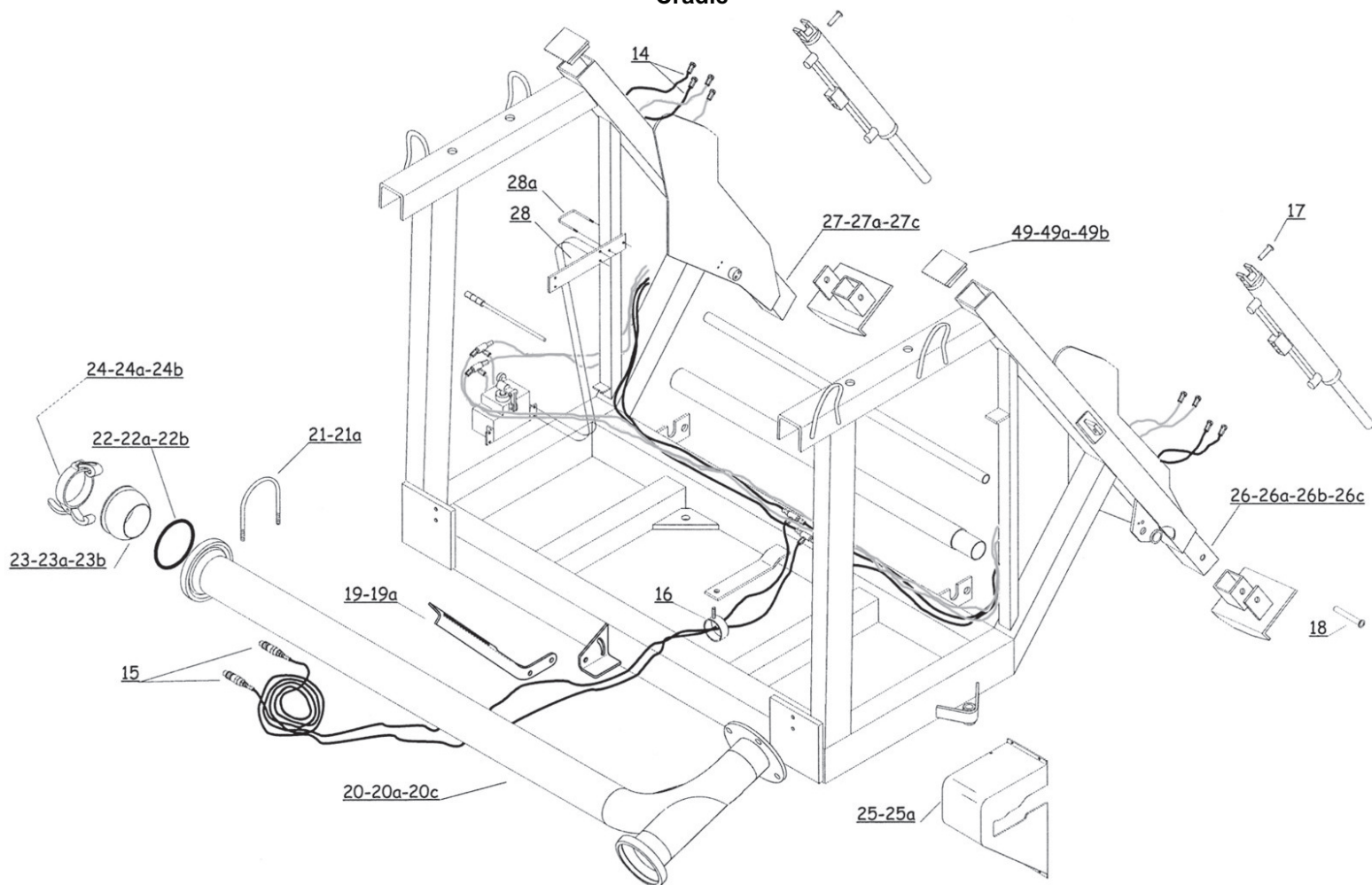

Item	Part Number	Description		
15	02210390	QUICK COUPLER-HOSE 1/2" MALE		1
16	02209000	SUPPORT, HYD HOSE		1
17	02208930	PIN, UPPER CYLINDER - AR5/6/7		2
18	02208940	PIN, 25MM X 170MM		2
19	02218750	DOUBLE SUPPLY SUPPORT ST4-ST5		1
19a	02218751	DOUBLE SUPPLY SUPPORT ST6-ST7		1
20	02218760	DOUBLE SUPPLY PIPE 3"1/2 ST4-5-6		1
20a	02218761	DOUBLE SUPPLY PIPE 4" ST5-6		1
20c	02218762	DOUBLE SUPPLY PIPE 5" ST7		1
21	02218770	U-BOLT M8 3"1/2		2
21a	02218771	U-BOLT M8		2
22	58800263	SEAL RING 3.5" 5.25ODX.5		2
22a	58800233	SEAL RING 4" 6-3/8 OD X 9/16		2
22b	58800243	SEAL RING 5" 7-1/2 OD X 3/4" CS		2
23	02218780	PLUG 3"1/2		1
23a	59703120	PLUG,WITH LEVER,BALL 4"		1
23b	02218782	PLUG 5"		1
24	58800261	LEVER RING 3.5IN 89MM		1
24a	58800231	this part is welded to # 23 on the 4" only		1
24b	58800241	LEVER RING 5" 451 133MM		1
25	02214500	SHIELD, BELT IRCO		1
25a	02214500	SHIELD, BELT B600		1

Cradle

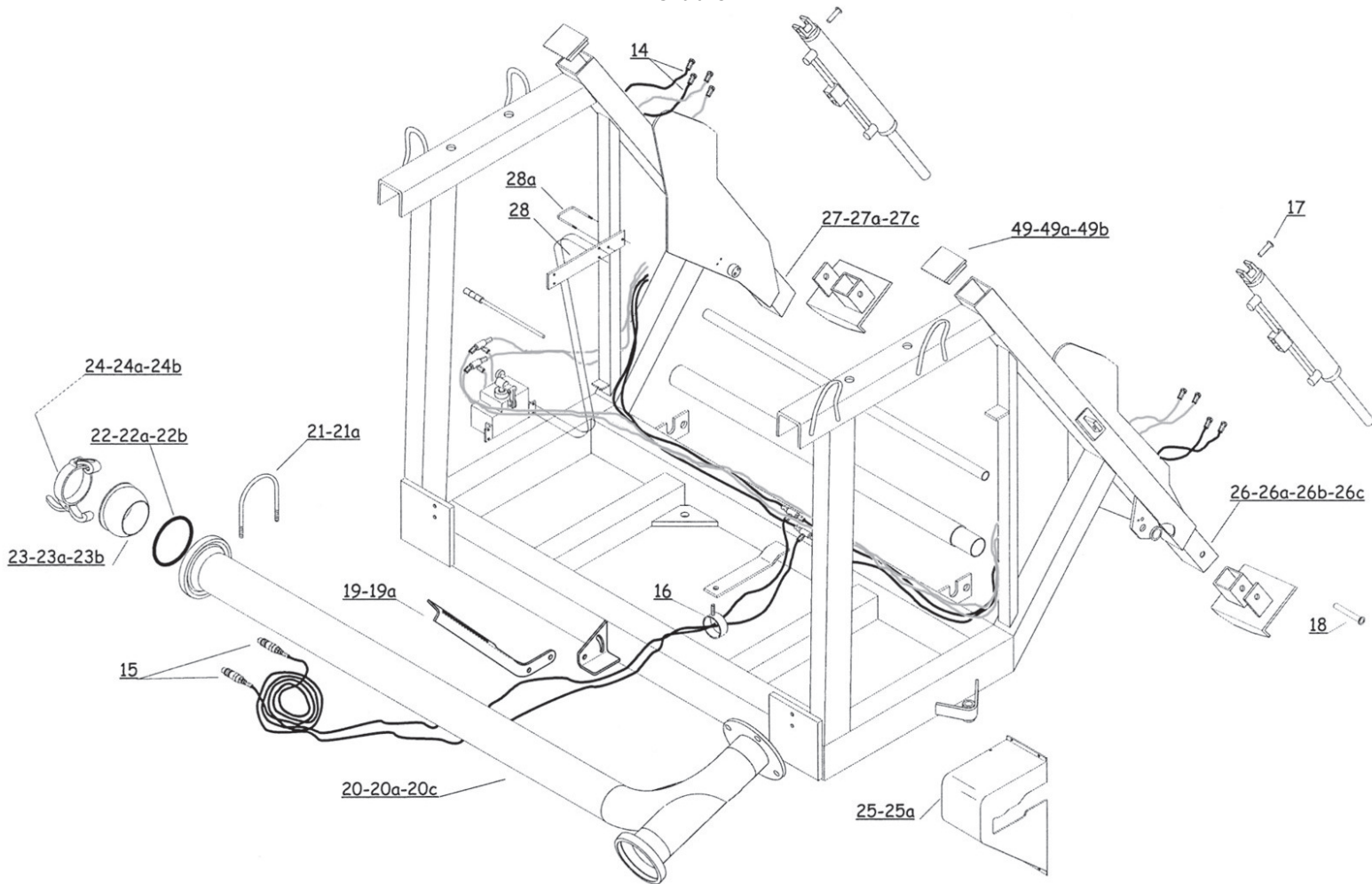

26	02210730	LEG,TS STABILIZER-AG4/AR4/(A1 380+)		1
26a	02211600	LEG, TURBINE-SIDE STABILIZER-AR5		1
26b	02211571	HYDRAULIC LEG FOR ST6		1
26c	02216980	HYDRULIC LEG AG7		1
27	02210740	LEG,CS STABILIZER-AG4/AR4/(A1 380+)		1
27a	02216892	HYDRAULIC LEG ST5		1
27c	02216981	HYDRAULIC LEG AG7		1
28	02218800	PUMP SUPPORT PLATE		1
28a	02214100	U-BOLT, M10		1
49	02209950	PLUG 70 X 70 ST4		1
49a	02209951	CAP PLUG 80MM X 80MM ST5-6		1
49b	02209952	CAP PLUG 100MM X 80MM		1

Cradle

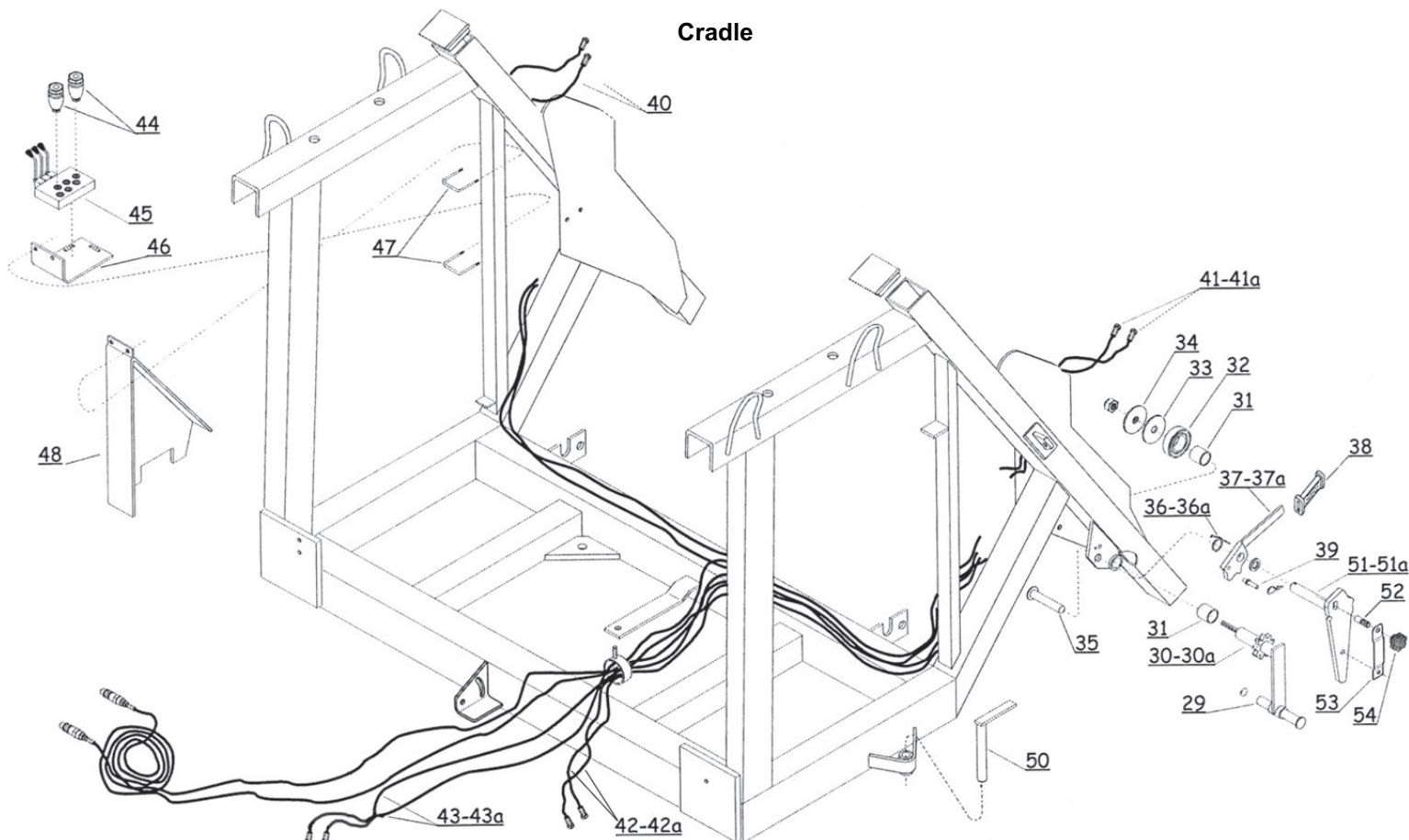

Item	Part Number	Description		
29	02099048	HANDLE		2
30	02099578	CRANK AG4		2
30a	02200060	CRANK AG5-AG6		2
31	02099056	BEARING,BRZ		4
32	02099059	SPRING, RUBBER STABILIZER		2
33	02099049	WASHER		2
34	02099058	NUT		2
35	02216990	PIN, DIA. 20MM X 100MM LONG		1
36	02099028	SPRING,RIGHT		1
36a	02099029	SPRING,LEFT		1
37	02099027	PAWL,RIGHT		1
37a	02199027	PAWL,LEFT		1
38	02204140	GRIP, TURBINE		2
39	02000026	PIN		2
40	02212800	HOSE, HYD R1T EL X STR 0.7M AG4-5-6-7		2
41	02212801	HOSE, HYD R1T EL X STR 3.0M ST4-5-6		2
41a	02214560	HOSE, HYD R1T EL X STR 3.0M AG5-6		2
42	02208912	HOSE ASM, TS HYD CYL. 3.0M- AG4		2
42a	02218810	HOSE ASM, TS HYD CYL. 3.4M- AG5-6-7		2
43	02212820	HOSE ASSEMBLY-R1T 90 X STR 3.7M AG4		2
43a	02208914	HOSE ASM, JACK - AR-SERIES		2
44	02212870	CONTROL, HYD. FLOW - A-SERIES		2
45	02212721	VALVE, 3 SECTION HYD DIRECTIONAL		1
46	02214090	BRACKET, 3-LEVER VALVE - AR-SERIES		1
47	02214100	U-BOLT, M10		2
48	02214080	COVER, 3-LEVER VALVE - A-SERIES		1
50	02217000	STOP TURRET PIN		1
51	02217860	STOP LEVER FOR US TS		1
51a	02217870	STOP LEVER FOR US CS		1
52	02217880	FIX STOPLEVER US		2
53	02217890	SPRING, 30 X 1 L:100 US		2
54	02217900	HAND GRIP M8		2

Spool

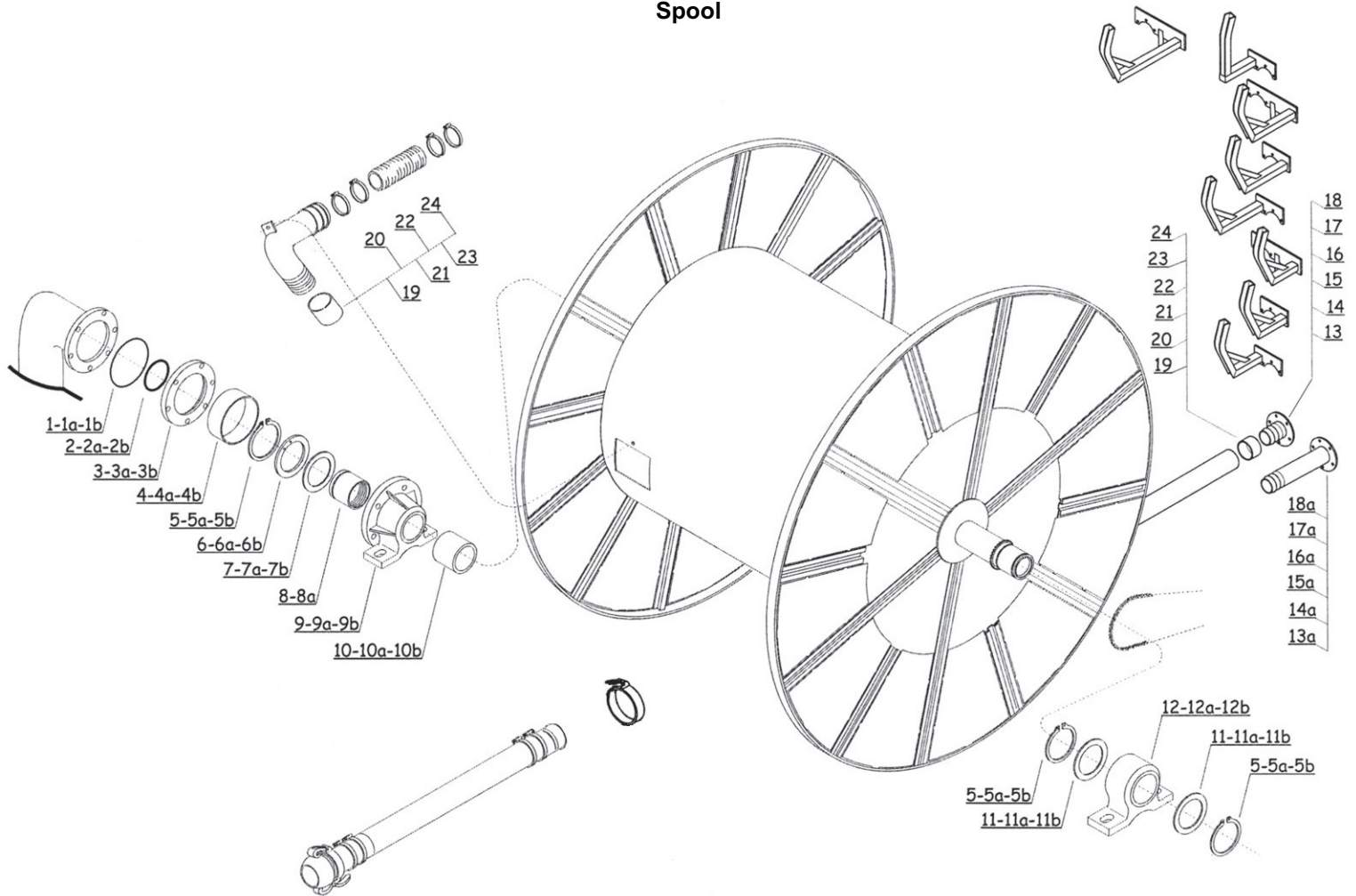

Item	Part Number	Description		
1	02204840	O-RING 104MM X 3.53MM ST4		1
1a	02200390	O-RING 5-1/8"OD X 1/8" CS ST5		1
1b	02204861	O-RING 154MM ID X 3.53MM		1
2	02210100	O-RING, 69.22MM X 5.33MM ST4		1
2a	02210370	O-Ring, 3.35" ID X .210" CS ST5		1
2b	02208420	O-RING 6MMX110MM ST6-7		1
3	02214462	RING, SEALING ST4		1
3a	02214461	RING, SEALING ST5		1
3b	02214460	RING, SEALING ST6-7		1
4	02206990	SPACER ST4		1
4a	02214020	SPACER, ST5		1
4b	02207541	SPACER ST6-7		1
5	02000428	SNAP RING 65 MM ST4		3
5a	02200370	Snap Ring E85 (AG5)		3
5b	02099061	SNAP RING E-110 (AG6-7)		3
6	02000439	Washer Thrust, (AG4)		1
6a	02211880	Washer Thrust, (AG5)		1
6b	02200090	Washer Thrust, (AG6-7)		1
7	02000441	Washer, Wear (AG4)		1
7a	02200360	Washer, Wear (AG5)		1
7b	02200100	Washer, Wear (AG6-7)		1
8	59302451	Ring Nut, Slip Joint (AG5)		1
8a	59302450	Ring Nut, Slip Joint (AG6-7)		1
9	02000442	Bearing, Flanged (AG4)		1
9a	02200320	Bearing, Flanged (AG5)		1
9b	02200130	Bearing, Flanged (AG6-7)		1

Spool

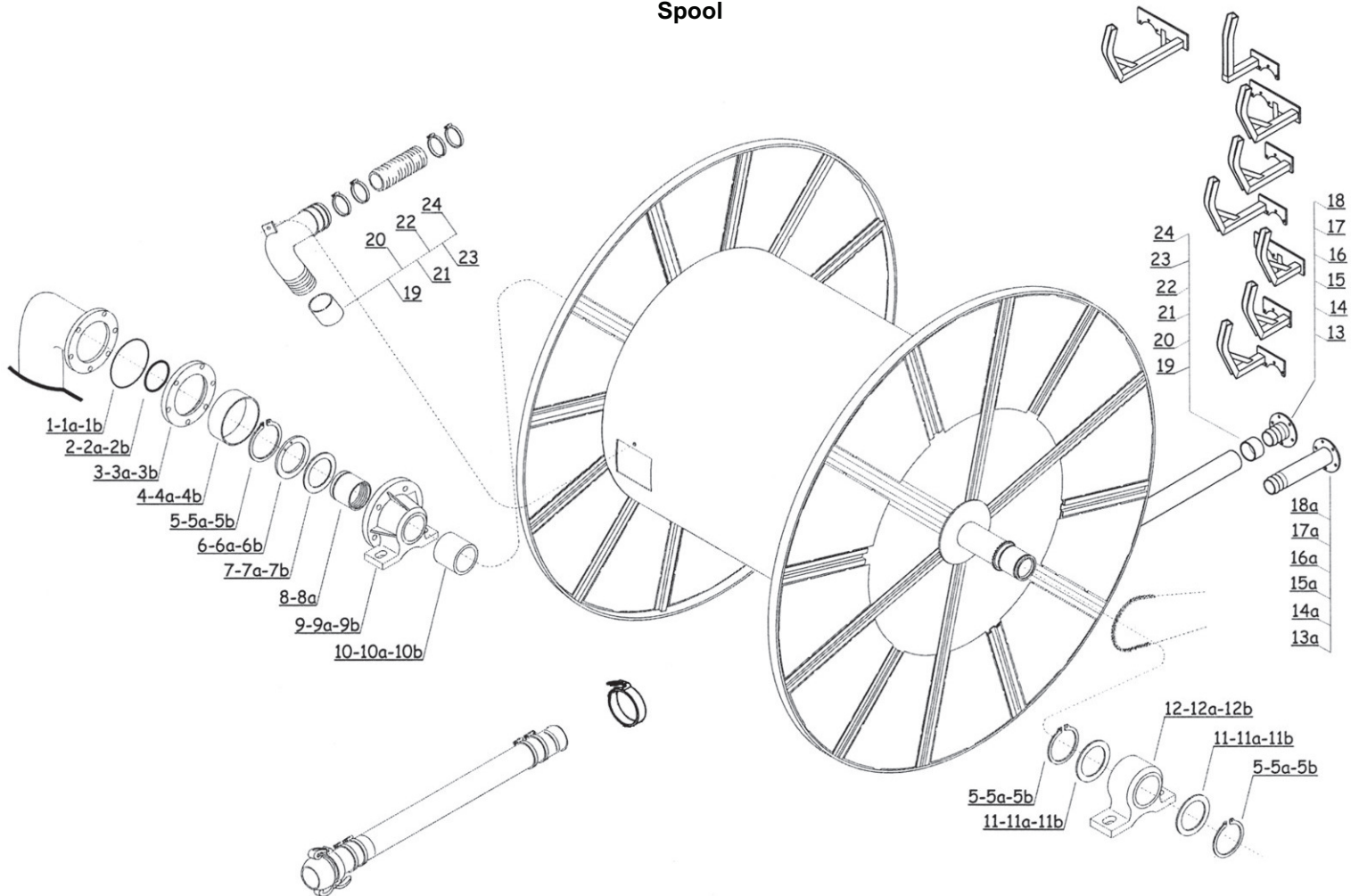

Item	Part Number	Description		
10	02210780	Sleeve (AG4)		1
10a	02211610	Sleeve (AG5)		1
10b	02213850	Sleeve (AG6-7)		1
11	02000429	Spacer (AG4)		2
11a	02200380	Spacer (AG5)		2
11b	02217930	SPACER, ST6-7		2
12	02000430	Support Bearing ST4		1
12a	02099581	Support Bearing ST5		1
12b	02200150	Support Bearing ST6-7		1
13	02218820	75MM HOSE END WITH FLANGE AND STOP		1
13a	02207405	75MM HOSE END WITH FLANGE W/O STOP		1
14	02218821	82MM HOSE RING WITH FLANGE HYDR./MAN		1
14a	02207404	82MM HOSE END WITH FLANGE W/O STOP		1
15	02218822	90MM HOSE END WITH FLANGE HYDR./MAN		1
15a	02207403	90MM HOSE END WITH FLANGE W/O STOP		1
16	02218823	100MM HOSE RING WITH FLANGE HYDR./MAN		1
16a	02207402	100MM HOSE END WITH FLANGE W/O STOP		1
17	02218824	110MM HOSE RING WITH FLANGE HYDR./MAN		1
17a	02207401	110MM HOSE END WITH FLANGE W/O STOP		1
18	02218825	120MM HOSE RING WITH FLANGE HYDR./MAN		1
18a	02207400	120MM HOSE END WITH FLANGE W/O STOP		1
19	02099450	Hose Band, 75mm		2
20	02099112	Band, Hose 82mm		2
21	02099113	Band, Hose 90mm		2
22	02099114	Band, Hose 100mm		2
23	02099115	Band, Hose 110mm		2
24	02003833	Band, Hose 120mm		2

Spool

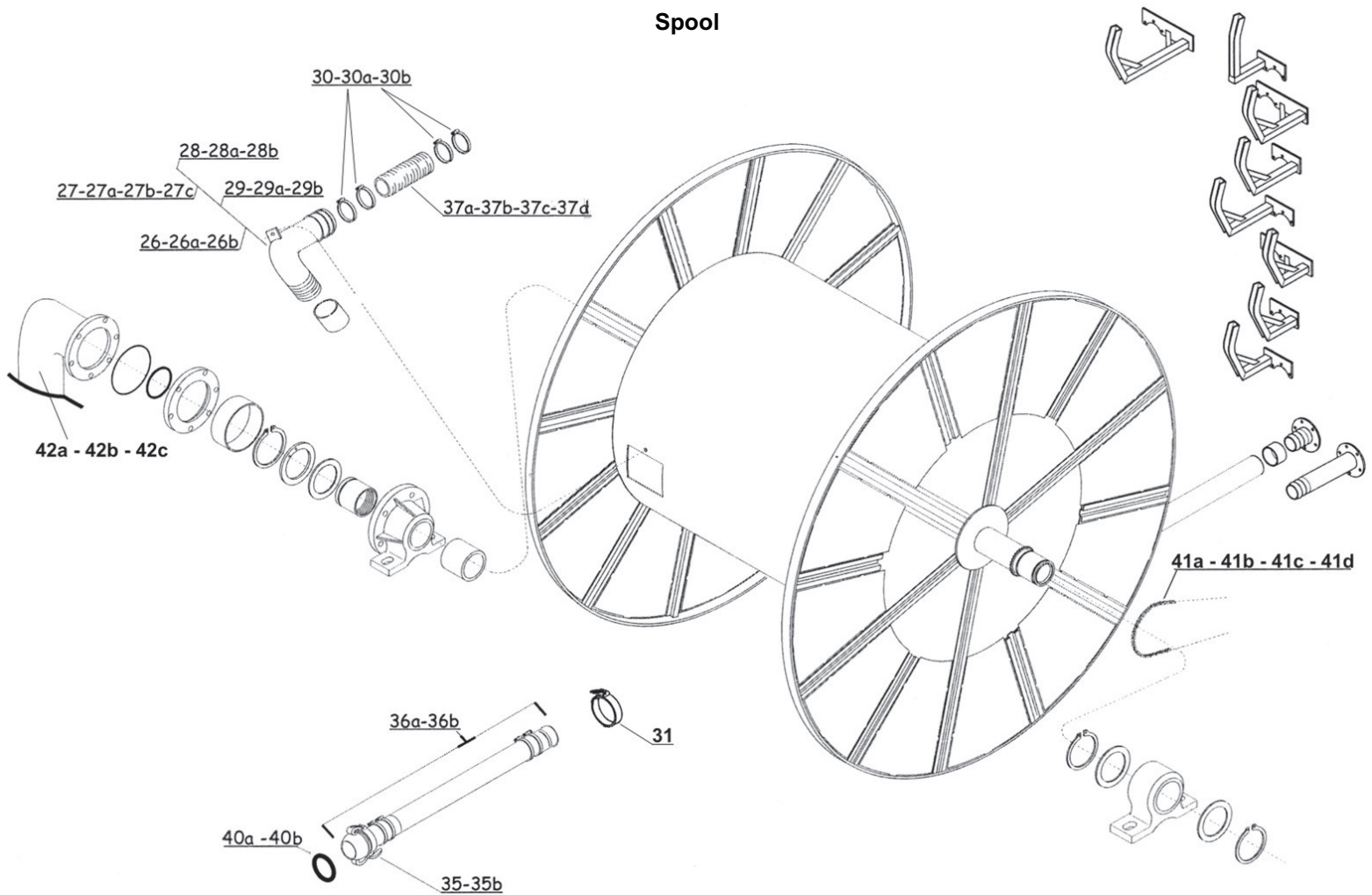

Item	Part Number	Description		
26	02210811	ELBW, ST4 75MM		1
26a	02210810	ELBOW, 82MM, ST4		1
26b	02212290	ELBOW, 90MM, ST4		1
27	02212530	ELBOW, 82MM, ST5		1
27a	02211620	ELBOW, 90MM, ST5		1
27b	02212300	ELBOW, 100MM, ST5		1
27c	02212151	ELBOW, 110MM, ST5		1
28	02211622	ELBW,33 ST6		1
28a	02212150	ELBW,37 ST6		1
28b	02212152	ELBW,40 ST6		1
29	02213860	ELBW,100MM TUBE - ST7		1
29a	02213861	ELBW,AR7 110MM		1
29b	02213862	ELBW,AR7 120MM		1
30	03019194	SUPRA CLAMP 73MM-79MM ST4		4
30a	03019215	SUPRA CLAMP 85MM-91MM ST5		4
30b	03019258	SUPRA CLAMP 112MM-121MM ST6-ST7		4
31	40049270	BAND,RING LOCK 4 IN		1
35	58800221	LEVER RING 3" 451 76MM (ST4)		1
35b	58800231	LEVER RING 4" 451 108MM		1
36a	58802841	HOSE ASSY,SUPPLY 3"X30FT (AG4)		1
36b	58802840	HOSE ASSY,SUPPLY 4"X30FT (AG5,6,7)		1
36c	25249622	HOSE, IRR SUPPLY REMNANT 3"(PERFT) (AG4) (hose only)	ft.	30
36d	25249620	HOSE, IRR SUPPLY REMNANT 4"(PERFT) (AG5,6,7) (hose only)	ft.	30
36e	030-1924-0	Clamp, Supra 104mm-112mm (for 4"Supply Hose only) not shown		4

Spool

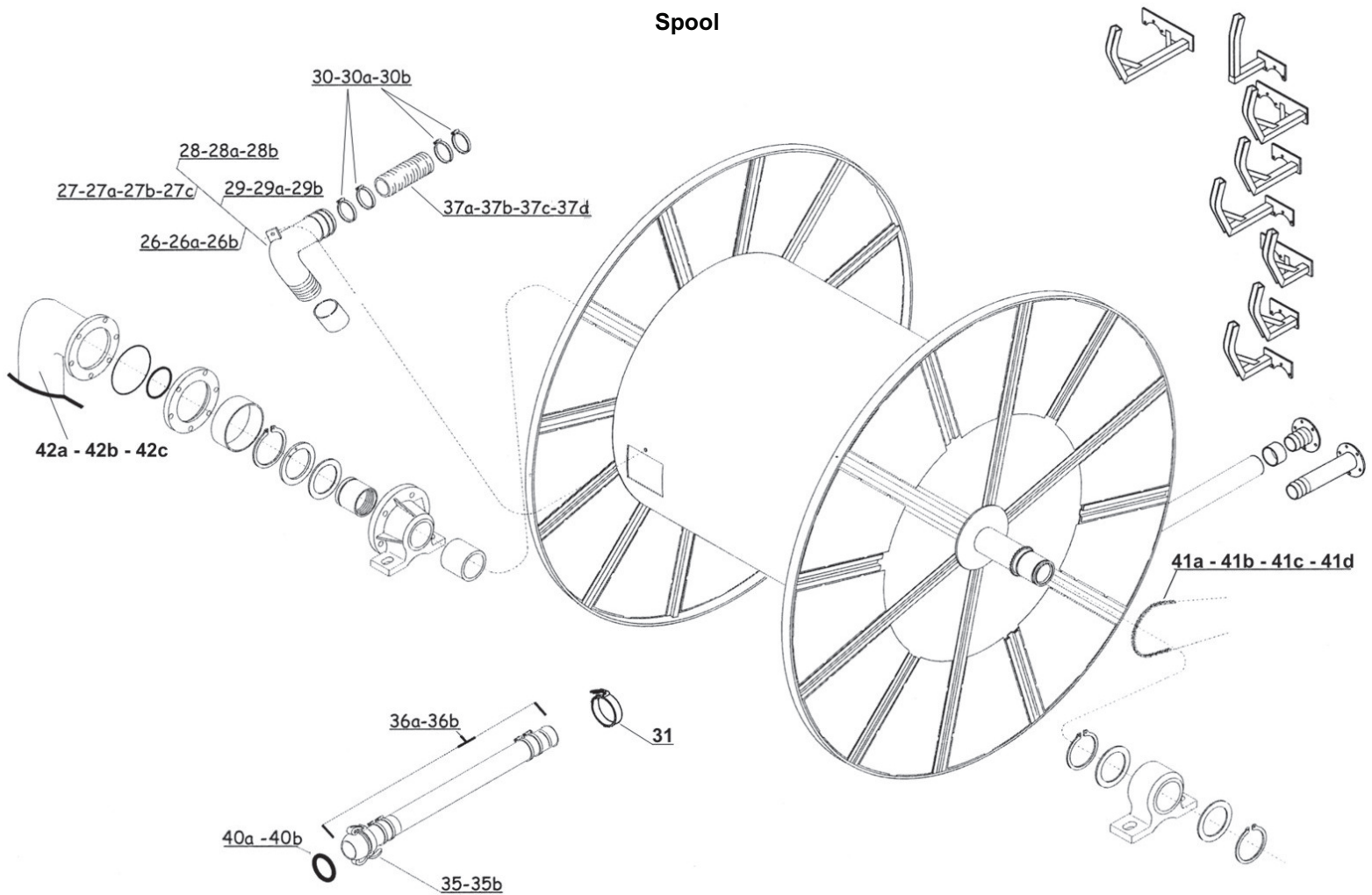

37a	02201480	HOSE, 70X79MM -0,6-4M (23.7") LONG (ST4)		1
37b	02200310	HOSE, 80X98MM -0,6-4M (32.287") LONG (ST5)		1
37c	02216271	HOSE 100 X 118 X .55M (21.65") LONG (ST6)		1
37d	02216270	HOSE 100 X 118 X .7M (27.6") LONG (ST7)		1
40a	58800233	O-Ring 4" (AG5,6,7) (not shown)		1
40b	58800223	O-Ring 3" (AG4) (not shown)		1
41a	02001140	Chain 1/2" 243p (244 Rollers AG4)	ft.	10.13
41b	02001140	Chain 1/2" 263p (264 Rollers AG5)	ft.	10.96
41c	02001140	Chain 1/2" 295p (296 Rollers AG6)	ft.	12.29
41d	02001140	Chain 1/2" 315p (316 Rollers AG7)	ft.	13.13
42a	02211150	ELBW,UPPER (COMER BOX)-AR4		1
42b	02211840	ELBW,UPPER 6"FLNG TO WELD(COMER)AR5		1
42c	02212100	ELBW,UPPER AR6-7		1

Spool

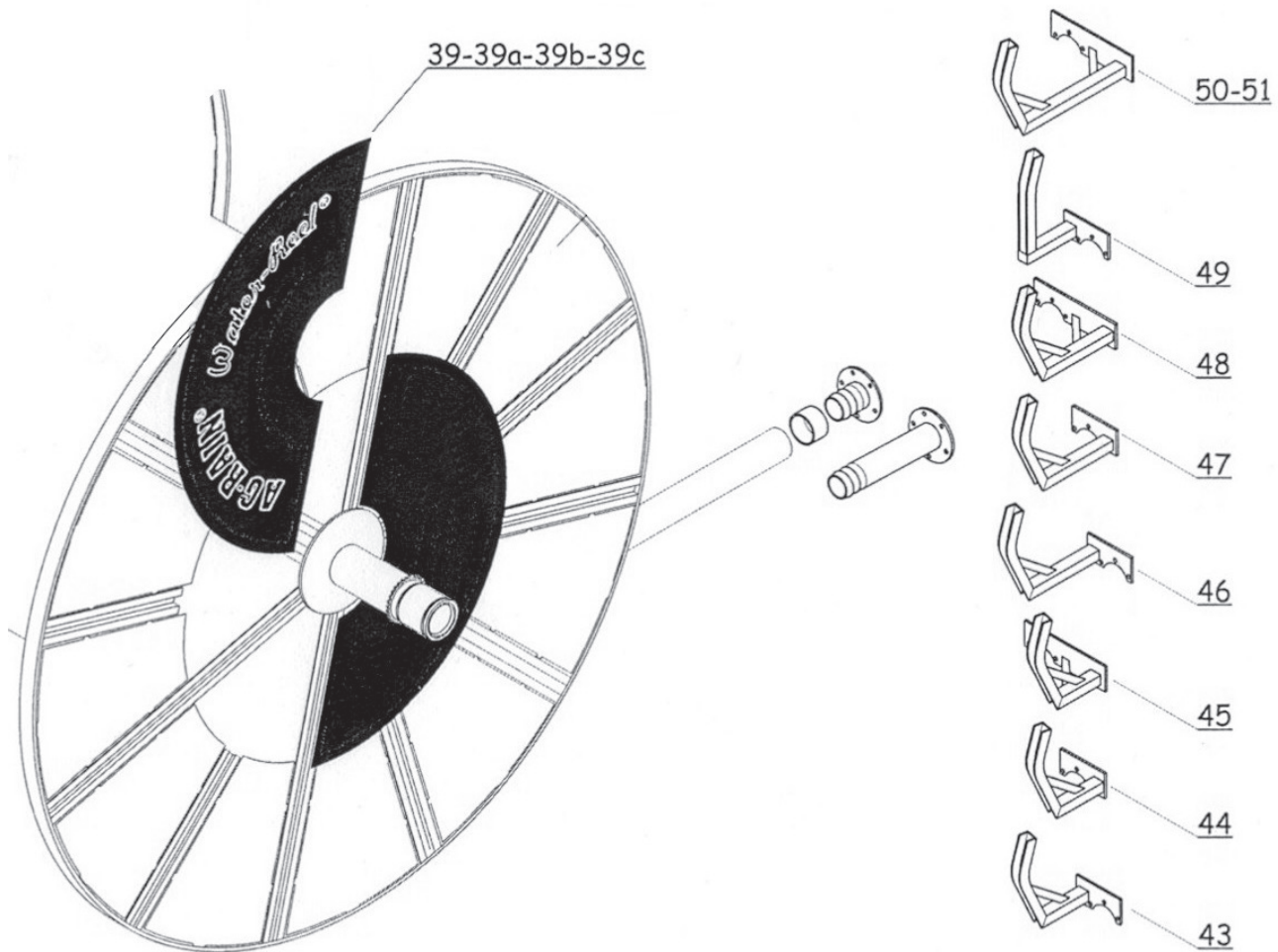

Item	Part Number	Description		
39	50301800	SHIELD, SPOOL AG4 KIFCO AG-RAIN		4
39a	50301801	SHIELD, SPOOL AG5/5+ KIFCO AG-RAIN		4
39b	50301802	SHIELD, SPOOL AG6 KIFCO AG-RAIN		4
39c	50301803	SHIELD, SPOOL ST7 KIFCO AG-RAIN		4
43	02218690	END SWITCH BAR CS ST4-5		1
44	02218691	END SWITCH BAR TS ST4-5		1
45	02218692	END SWITCH BAR BEVEL GEAR ST4-5		1
46	02218693	END SWITCH BAR CS ST6-7		1
47	02218694	END SWITCH BAR TS ST6-7		1
48	02218695	END SWITCH BAR BEVEL GEAR ST6-7		1
49	02218696	END SWITCH BAR SEMI-AUTO ST6-7		1
50	02218697	END SWITCH BAR IRRIGATION BOOM ST6-7		1
51	02218698	END SWITCH BAR IRRIGATION BOOM ST5		1

Levelwind

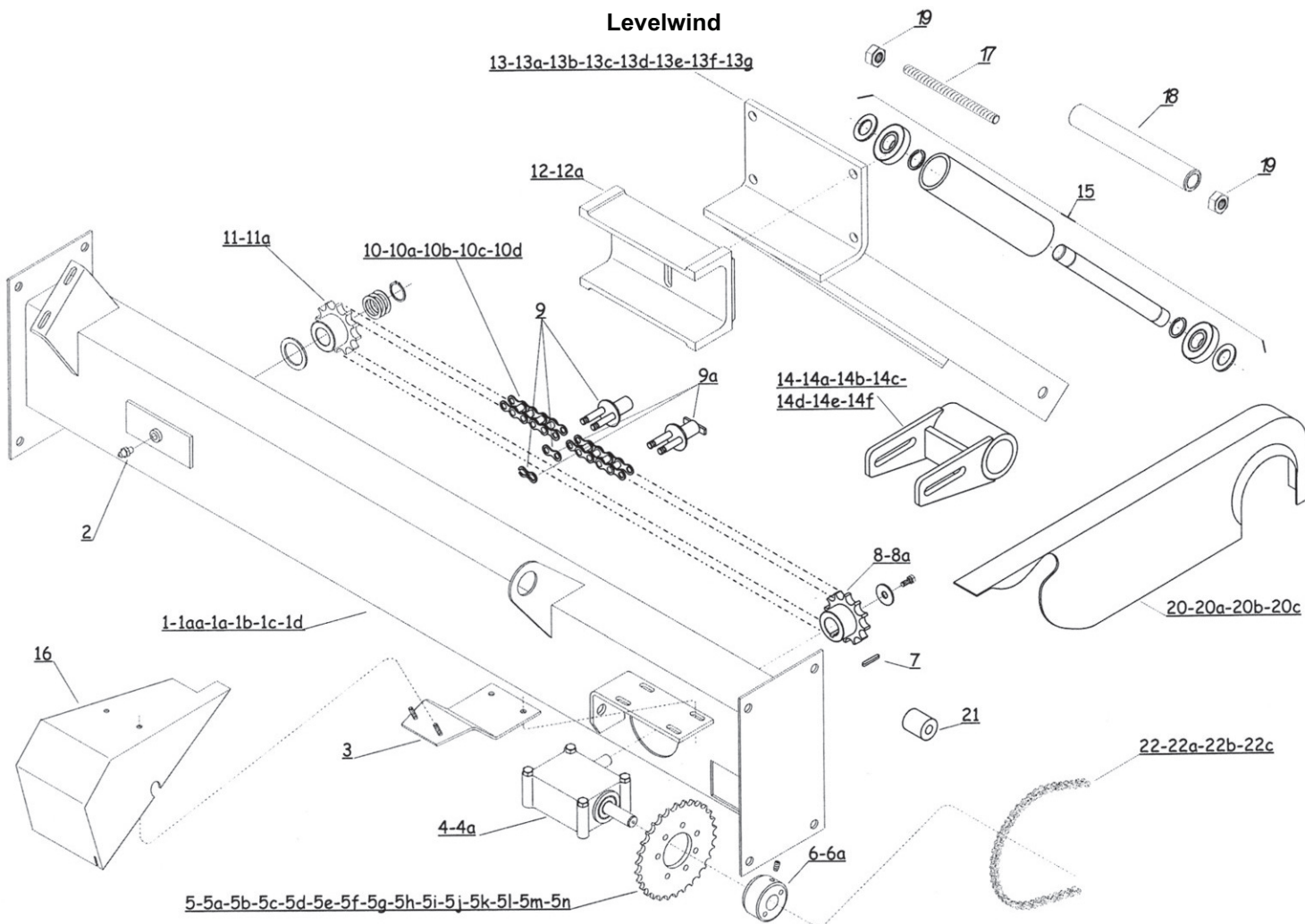

Item	Part Number	Description	Qty.
1	02210910	LEVELWIND FRAME -AR4 49" OAL	1
1aa	02219940	LEVELWIND FRAME -ST4 54.75" OAL	1
1a	02211630	LEVELWIND FRAME - ST5	1
1b	02211910	FRAME, LEVELWIND - ST6	1
1c	02218850	HOSE GUIDE FRAME ST6 LARGE	1
1d	02210911	LEVELWIND FRAME -ST7	1
2		zerk	1
3	02210930	SHIELD MT.	1
4	02001085	GEARBOX,RIGHT ANGLE (ST4)	1
4a	02000154	GEARBOX - LEVELWIND (CAST) (ST5-6-7)	1
5	02203863	SPRKT, 1/2" X 36 TOOTH FOR HOSE DIA. 63MM (ST4)	1
5a	02203861	SPRKT, 1/2" X 32 TOOTH FOR HOSE DIA. 70MM (ST4)	1
5b	02000482	SPRKT, 1/2" X 30 TOOTH FOR HOSE DIA. 75MM (ST4)	1
5c	02203864	SPRKT, 1/2" X 27 TOOTH FOR HOSE DIA. 82MM (ST4)	1
5d	02201250	SPRKT, 1/2" X 25 TOOTH FOR HOSE DIA. 90MM (ST4)	1
5e	02008670	SPRKT, 1/2" X 43 TOOTH FOR HOSE DIA. 75MM (ST5)	1
5f	02210950	SPRKT, 1/2" X 39 TOOTH FOR HOSE DIA. 82MM (ST5)	1
5g	02211640	SPRKT, 1/2" X 35 TOOTH FOR HOSE DIA. 90MM (ST5)	1
5h	02203862	SPRKT, 1/2" X 31 TOOTH FOR HOSE DIA. 100MM (ST5)	1
5i	02201240	SPRKT, 1/2" X 29 TOOTH FOR HOSE DIA. 110MM (ST5)	1
5j	02203865	SPRKT, 1/2" X 50 TOOTH FOR HOSE DIA. 82MM (ST6)	1
5k	02099156	SPRKT, 1/2" X 45 TOOTH FOR HOSE DIA. 90MM (ST6)	1
5l	02099157	SPRKT, 1/2" X 40 TOOTH FOR HOSE DIA. 100MM (ST6-7)	1
5m	02203863	SPRKT, 1/2" X 36 TOOTH FOR HOSE DIA. 110MM (ST6-7)	1
5n	02004610	SPRKT, 1/2" X 33 TOOTH FOR HOSE DIA. 120MM (ST6-7)	1
6	02000153	HUB, SPROCKET	1
6a	02208410	DOUBLE HUB, SPROCKET	1
7	02207880	KEY, 7MM X 8MM X 25MM	1

Levelwind

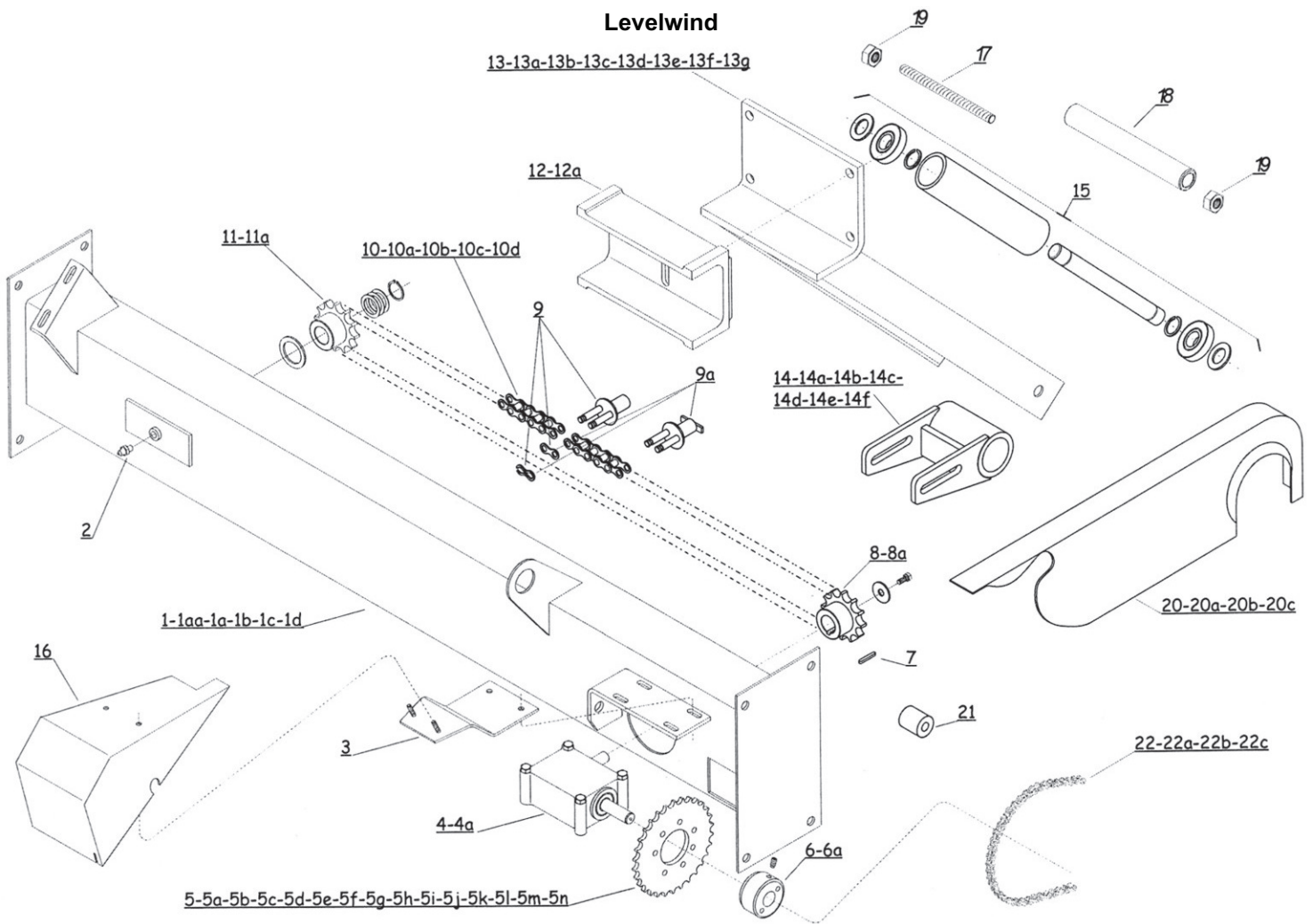

8	02209040	SPROCKET, 10 TOOTH 1.0" PITCH		1
8a	02000479	SPRKT,LVLWND DRIVER 13T 5/8"		1
9	02209051	LINK, HOSE GUIDE, OVAL END, 1"		1
9a	02209050	LINK, HOSE GUIDE, OVAL END, 5/8"		1
10	02001141	CHAIN 5/8 METRIC ROLLER PER FT. 117 p (ST4)	ft.	6.09
10a	87548482	CHAIN 1.0" PER FOOT 85P (ST5)	ft.	7.08
10b	87548482	CHAIN 1.0" PER FOOT 84P (110DIA.) (ST5)	ft.	7.0
10c	87548482	CHAIN 1.0" PER FOOT 91P (ST6)	ft.	7.58
10d	87548482	CHAIN 1.0" PER FOOT 99P (ST7)	ft.	8.25
11	02000475	SPRKT,LVLWND IDLER 13T (ST4)		1
11a	02099148	SPRKT,IDLER 80B10T 25MM		1
12	02210970	SUPPORT, FORK - ST4		1
12a	02209080	SUPPORT, FORK - ST5, ST6, ST7		1
13	02210981	FORK ASM, 75MM - ST4		1
13a	02210980	FORK ASM, 82-90MM - ST4		1
13b	02211661	FORK ASM, 75MM - ST5		1
13c	02211660	FORK ASM, 82-90MM - ST5		1
13d	02211662	FORK ASM, 100-110MM (4.5) - ST5		1
13e	02211932	FORK ASM, 100-110MM (141 DEG) - ST6		1
13f	02211931	FORK ASM, 120MM (141 DEG) - ST6		1
13g	02213871	FORK ASM, 120MM (137 DEG) - ST7		1
14	02210990	GUIDE, FORK 75, 82, 90 - ST4		1
14a	02210991	GUIDE, FORK 82, 90, 100 - ST5		1
14b	02210992	GUIDE, FORK 110 - ST5		1
14c	02212072	GUIDE, FORK 100/110 - ST6		1
14d	02212071	GUIDE, FORK 120 - ST6		1
14e	02218010	GUIDE, FORK 100-110 ST7		1
14f	02218011	GUIDE, FORK 120 ST7		1
15	02209110	ROLLER,VERT.		2

Levelwind

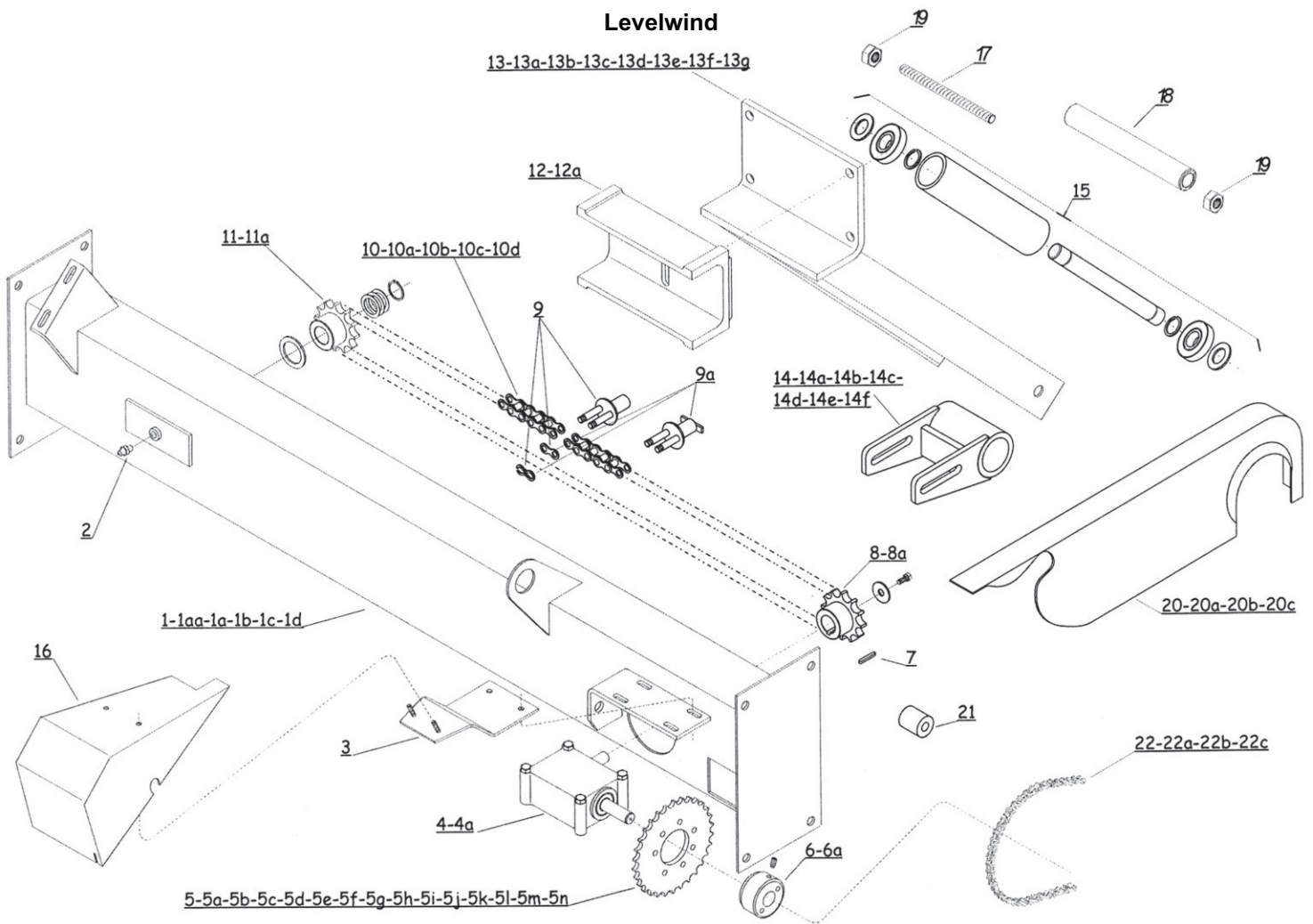

16	02211010	SHIELD, LEVELWIND GEARBOX		1
17	02201340	TIE ROD		1
18	02214060	SPACER, 90MMPE FORK (4.33")-ST4		1
18A	02214061	SPACER, 3"-3.3" AG5-AG5+ 3.6" LONG		1
18C	02214063	SPACER, 110MMPE FORK (8.86")-ST6		1
18D	02214064	SPACER, 120MMPE FORK (9.25")-ST7		1
19		NUT 16MM		2
20	02218860	SHIELD, LEVELWIND DRIVE, ST4		1
20a	02218861	SHIELD, LEVELWIND DRIVE, ST5		1
20b	02218862	SHIELD, LEVELWIND DRIVE, ST6		1
20c	02218863	GUARD, LEVELWIND CHAIN - ST7		1
21	02211040	CHAIN TIGHTENER		1
22	02001140	Chain 1/2" 243p (244 Rollers AR4)	ft.	10.13
22a	02001140	Chain 1/2" 263p (264 Rollers AR5)	ft.	10.96
22b	02001140	Chain 1/2" 295p (296 Rollers AR6)	ft.	12.29
22c	02001140	Chain 1/2" 315p (316 Rollers AR7)	ft.	13.13

HOSE RETENTION BAR ST4-5-6-7

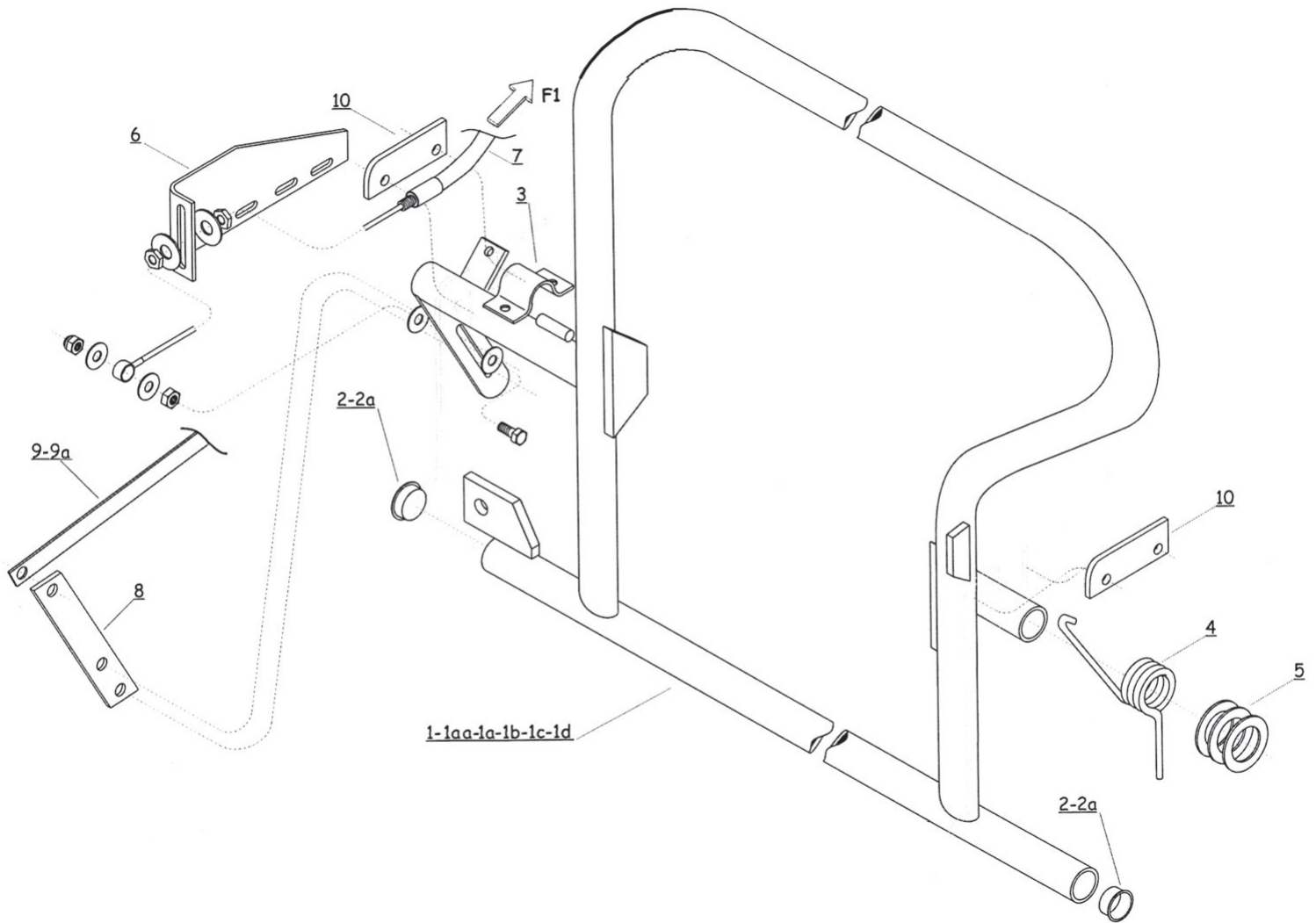

Item	Part Number	Description	Qty.
1	02217830	SHUTOFF BAR ST4 36.0" end to end on center pipe (axle)	1
1aa	02219930	SHUTOFF BAR ST4 (wider than above.)	1
1a	02217831	SHUTOFF BAR ST5	1
1b	02217832	SHUTOFF BAR AG6	1
1c	02217834	SHUTOFF BAR ST6 WIDE	1
1d	02217833	SHUTOFF BAR AG7	1
2	02218020	PLUG, FOR BAR ST4	2
2a	02218021	PLUG, FOR BAR ST5-6-7	2
3	02000164	RETAINER	1
4	02200166	SPRING, COIL - SHUT OFF	1
5	02211080	WASHER	3
6	02211090	CABLE MT.	1
7	02211471	CABLE,ENGINE THROTTLE-ST4/5/6(105")	1
8	02218030	HONDA ENGINE REGULATION ROD SUPPORT	1
9	02218031	HONDA ENGINE REGULATION ROD ST4-5	1
9a	02218032	HONDA ENGINE REGULATION ROD ST6-7	1

MANUAL LIFTING DEVICE

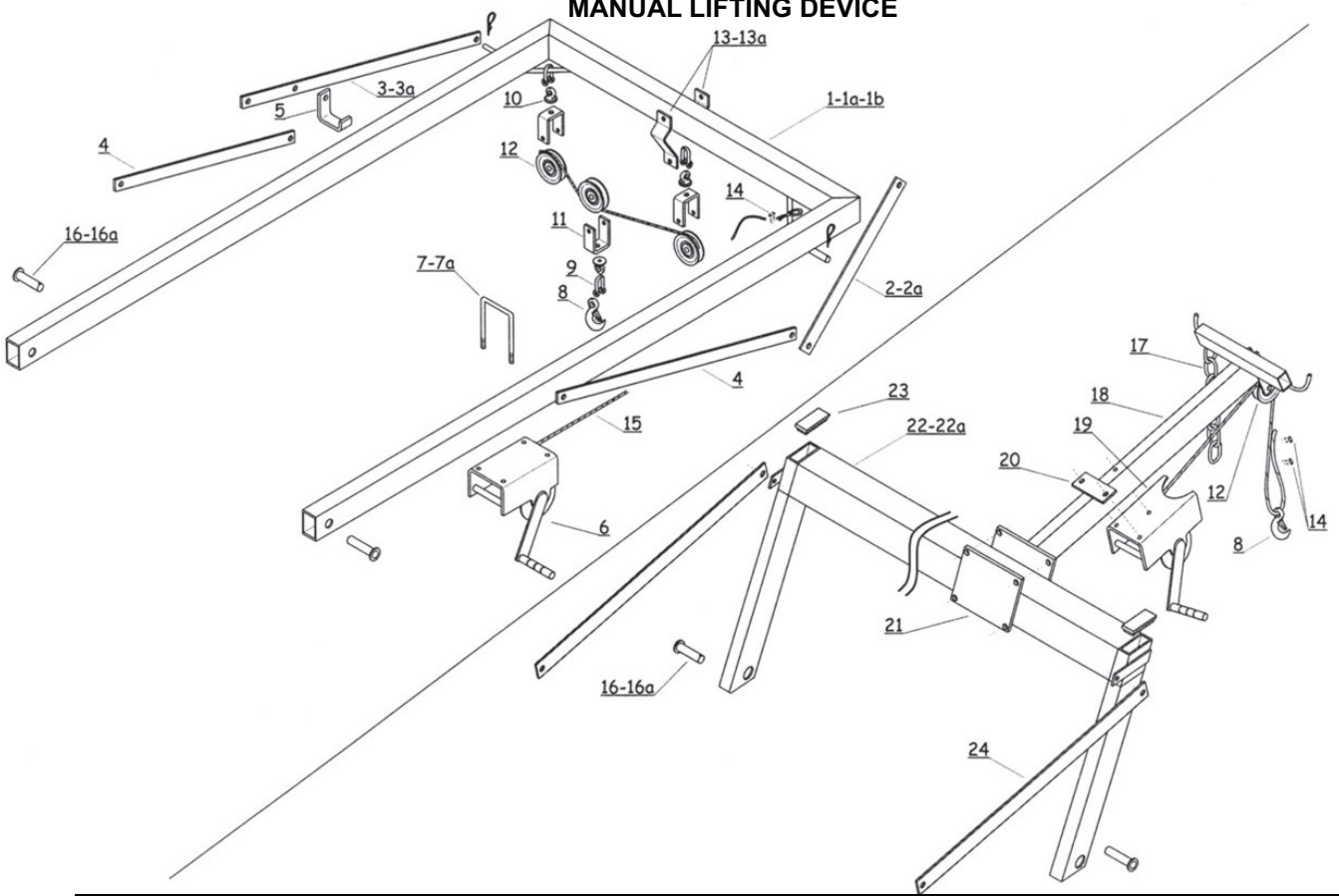

Item	Part Number	Description	Qty.
1	02218040	FIXED FRAME ST4	1
1a	02218041	FIXED FRAME ST5	1
1b	02218042	FIXED FRAME ST6	1
2	02218050	SUPPORT PLATE L.1230 ST4-5	1
2a	02218051	SUPPORT PLATE L.1480 ST6	1
3	02218060	SUPPORT PLATE L.1230 ST4-5	1
3a	02218061	SUPPORT PLATE L.1480 ST6	1
4	02218070	SUPPORT PLATE L.730 ST4-5-6	1
5	02218080	BRACKET	8
6	02218090	WINCH, K750	1
7	02218100	U-BOLT M8 ST5-6-7	2
7a	02218101	U-BOLT M8 ST4	2
8	02218110	HOOK	2
9	02218120	CLEVIS	4
10	02218130	EYE BOLT M12F	4
11	02218140	FORK	4
12	02218150	PULLEY	1
13	02218160	PULLEY SUPPORT ST5-6-7	1
13a	02218161	PULLEY SUPPORT ST4	1
14	56005270	CLAMP, 1/4 CABLE	2
15	75048440	CABLE, 1/4-7X19 GAC PER FT	ft. 27
16		PIN, 20MM X 85MM (AT40)	2
16a	02216990	PIN, DIA. 20MM X 100MM LONG	2
17	02209220	CHAIN, CART LIFT	1
18	02218170	LEVER SUPPORT (AG-RAIN)	1
19	02218180	WINCH K950 (AG-RAIN)	1
20	02218190	WINCH PLATE FIX (AG-RAIN)	1
21	02218191	LEVER SUPPORT PLATE FIX (AG-RAIN)	1
22	02218200	FIXED FRAME ST4 (AG-RAIN)	1
22a	02218201	FIXED FRAME ST5 (AG-RAIN)	1
23	02218210	PLUG 70X40	1
24	02218220	SUPPORT PLATE (AG-RAIN)	1

HYDRAULIC LIFTING DEVICE

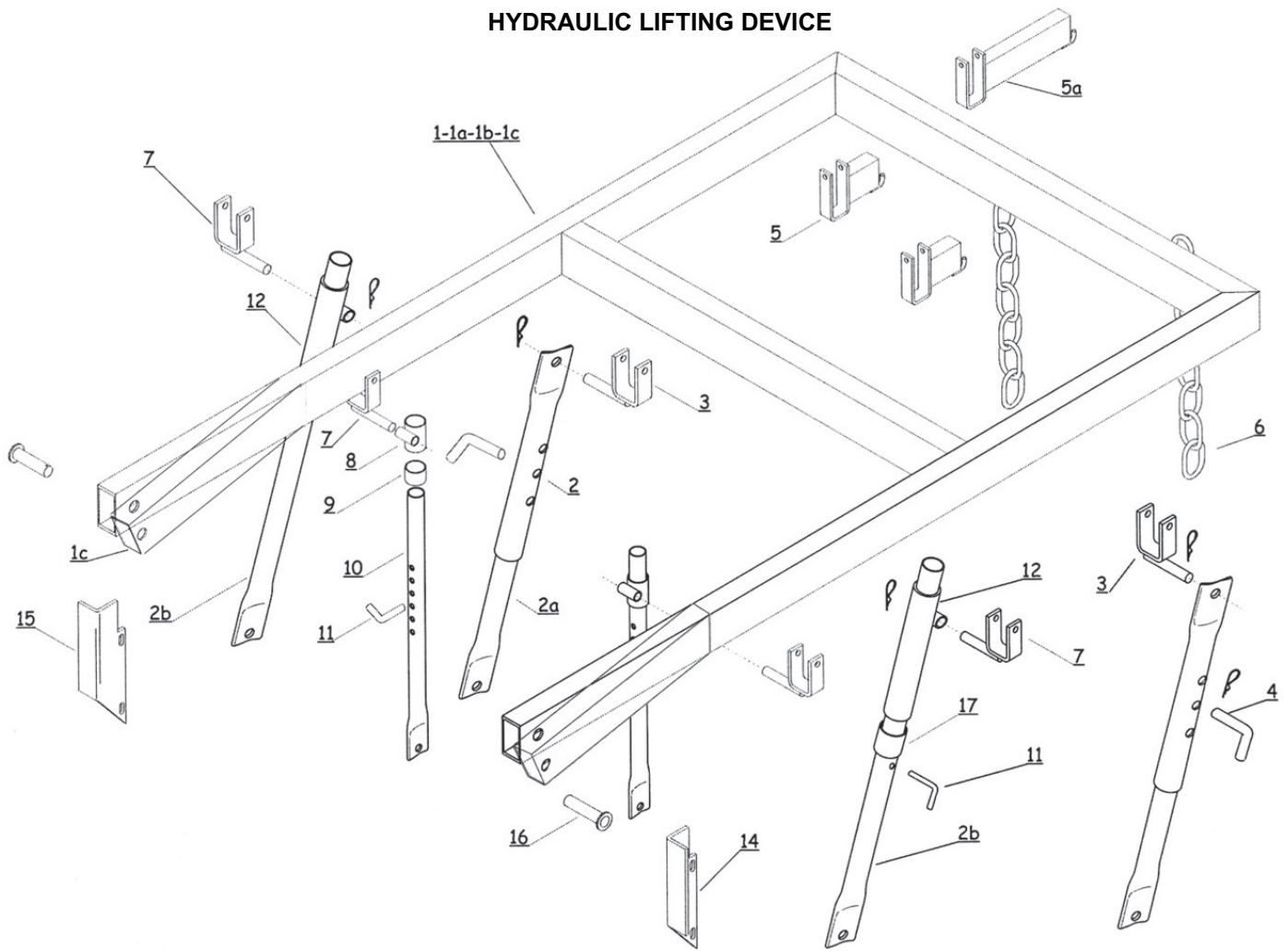

Item	Part Number	Description	Qty.
1	02212043	LIFTING FRAME ST4	1
1a	02212042	LIFTING FRAME ST5	1
1b	02212040	LIFTING FRAME ST6	1
1c	02212041	LIFTING FRAME ST7	1
2	02212053	LIFTING PROP ST4-5-6 L.1000	2
2a	02212054	LIFTING PROP ST4-5-6 L.1000	2
2b	02212051	BRACE, LIFT BAIL - ST7	2
3	02209190	BRACKET, FRAME LIFT - ST5/6/7	2
4	02209200	PIN, LIFT BRACE - ST5/6/7	2
5	02212060	HANGER	2
5a	02212061	HANGER ST4-5-6-7US	2
6	02209220	CHAIN, CART LIFT	1M
7	02209230	FORK, LIFT FRAME - ST4-5-6	2
8	02212160	FRONT BRACE HOLDER	2
9	02212170	SPACER	2
10	02212180	FRONT BRACE	2
11	02212190	PIN	2
12	02218240	AWL GUIDE ST7	2
14	02218250	STOP ROD ST7 TS	1
15	02218251	STOP ROD ST7 CS	1
16	02216990	PIN, DIA. 20MM X 100MM LONG	2

AUTMATIC LIFTING DEVICE ST4-5-6-7

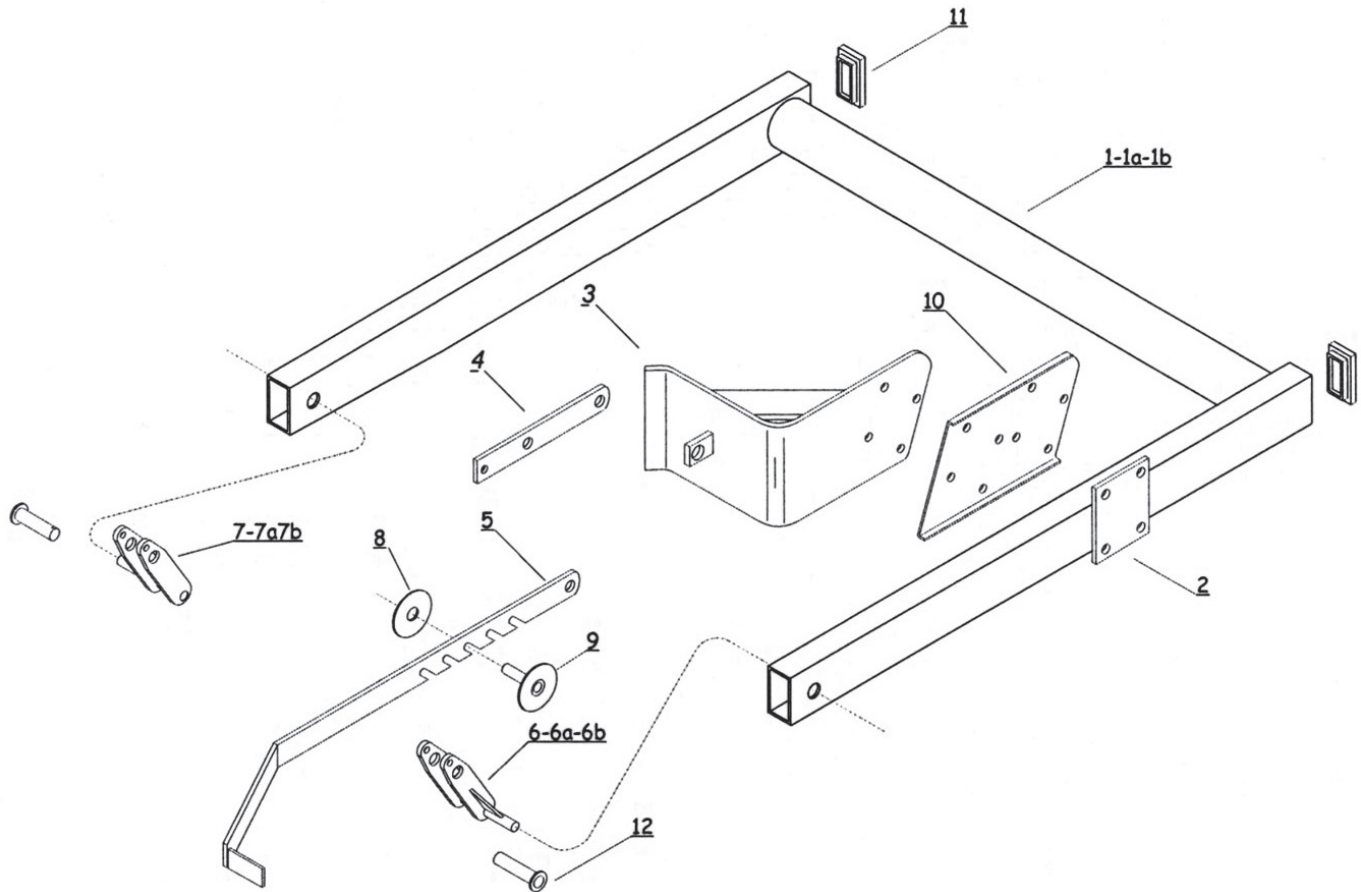

Item	Part Number	Description	Qty.
1	02218260	LIFTING FRAME ST4	1
1a	02218261	LIFTING FRAME ST5	1
1b	02218262	LIFTING FRAME ST6	1
2	02218270	CHECK PLATE SUPPORT ST4-5-6	1
3	02218280	CHECK PLATE ST4-5-6	1
4	02218290	STOP ROD PROLONG ST6	1
5	02218300	STOP ROD	1
6	02218310	LIFTING DEVICE SUPPORT TS ST4	1
6a	02218311	LIFTING DEVICE SUPPORT TS ST5	1
6b	02218312	LIFTING DEVICE SUPPORT TS ST6	1
7	02218320	LIFTING DEVICE SUPPORT CS ST4	1
7a	02218321	LIFTING DEVICE SUPPORT CS ST5	1
7b	02218322	LIFTING DEVICE SUPPORT CS ST6	1
8	02218330	DISK FOR SECURTY LEVER	1
9	02218340	SECURTY STOP	1
10	02218350	CHECK PLATE PROLONG	1
11	02218210	PLUG 70X40	2
12	02216990	PIN, DIA. 20MM X 100MM LONG	2

DRIVE TRAIN

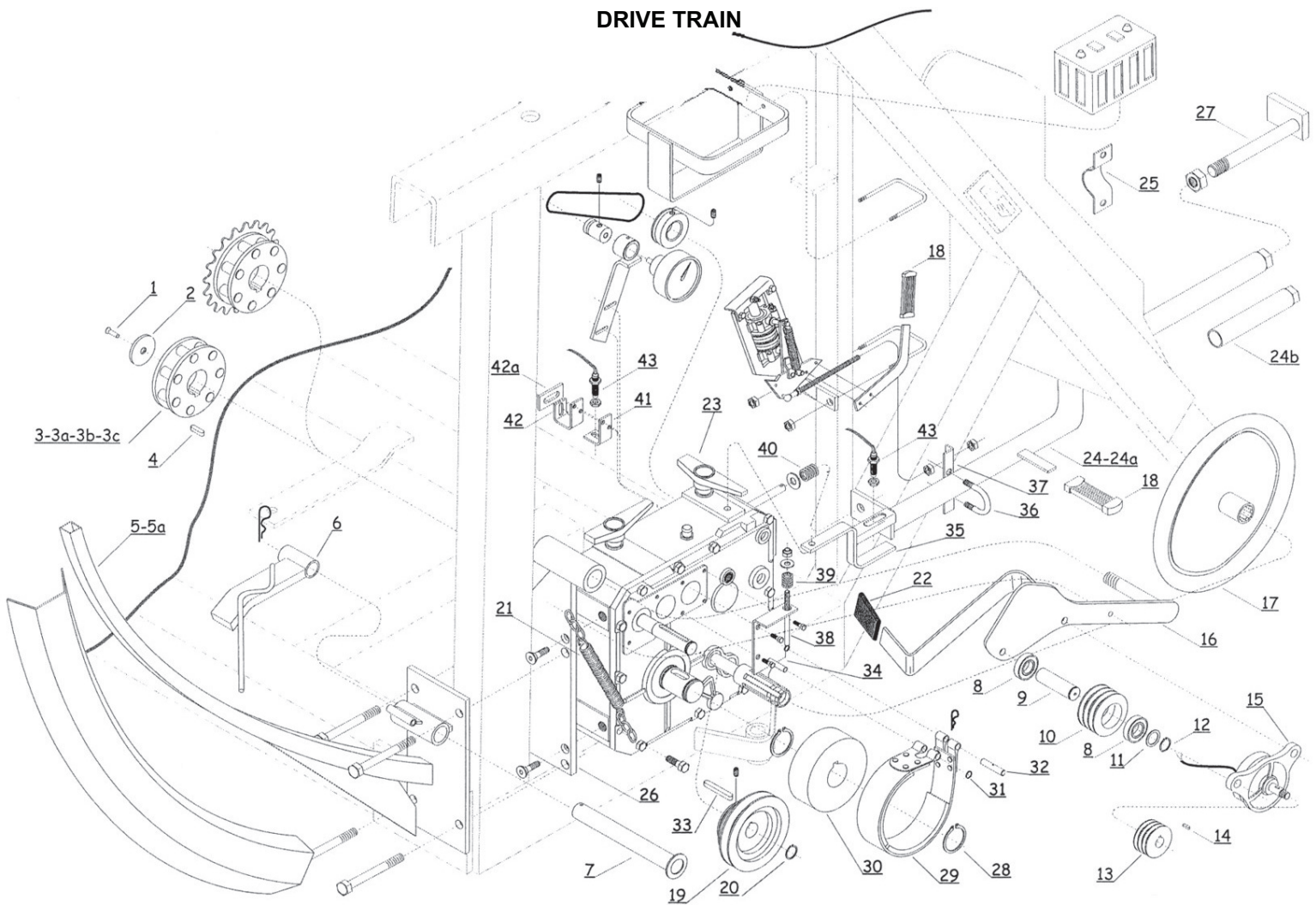

Item	Part Number	Description	Qty.
1a	55070112	SCREW 10MMX35MM ALEN FLAT (NOTE LENGTH)	1
1b	55070110	SCREW 10MMX25MM ALEN FLAT (NOTE LENGTH)	1
2	02203590	WASHER,SPECIAL	1
3	02211160	PINION, 35BORE 16PIN 115 OD Z7-AR4	1
3a	02211161	PINION, 35BR 16PIN 124OD Z7-AR5/A1	1
3b	02211162	PINION, 35BORE 20PIN 135 OD Z7-AR6	1
3c	02211163	PINION, 35BORE 20PIN 150 OD Z7-AR7	1
4	02218880	KEY, 10MM X 8MM X 40MM	1
5	02211170	GEARBOX PLATE AR4-5	1
5a	02211171	GEARBOX PLATE AR6-7	1
6	02211180	ANTI-RETURN PAWL	1
7	02203710	PIN,ANTI-RETURN PAWL AR4/5/6/7	1
8	02203440	BEARING,6005-2RS	2
9	02206530	SHAFT,BELT IDLER	1
10	02206540	PULLEY IDLER 3 GROOVE	1
11	02207030	SPACER 1MM X 25MM X 35MM	1
12	02203420	SNAP RING E25	1
13	02211190	ALTENATOR PULLEY	1
14	02211200	KEY 4MM X 4MM X 12MM	1
15	02211210	ALTENATOR	1
16	02211221	ARM, IDLER BIMA - AR4/5/6/7	1
17	50200050	WHEEL, PE TUBE HAND WIND	1
18	02204140	GRIP, TURBINE	1
19	02213980	PLLY,3 STEP 100M,125M,147	1
20	02201680	SNAP RING E20	1
21	02203180	SPRING BELT TIGHTENER	1
22	02211250	HAND GRIP	1

DRIVE TRAIN

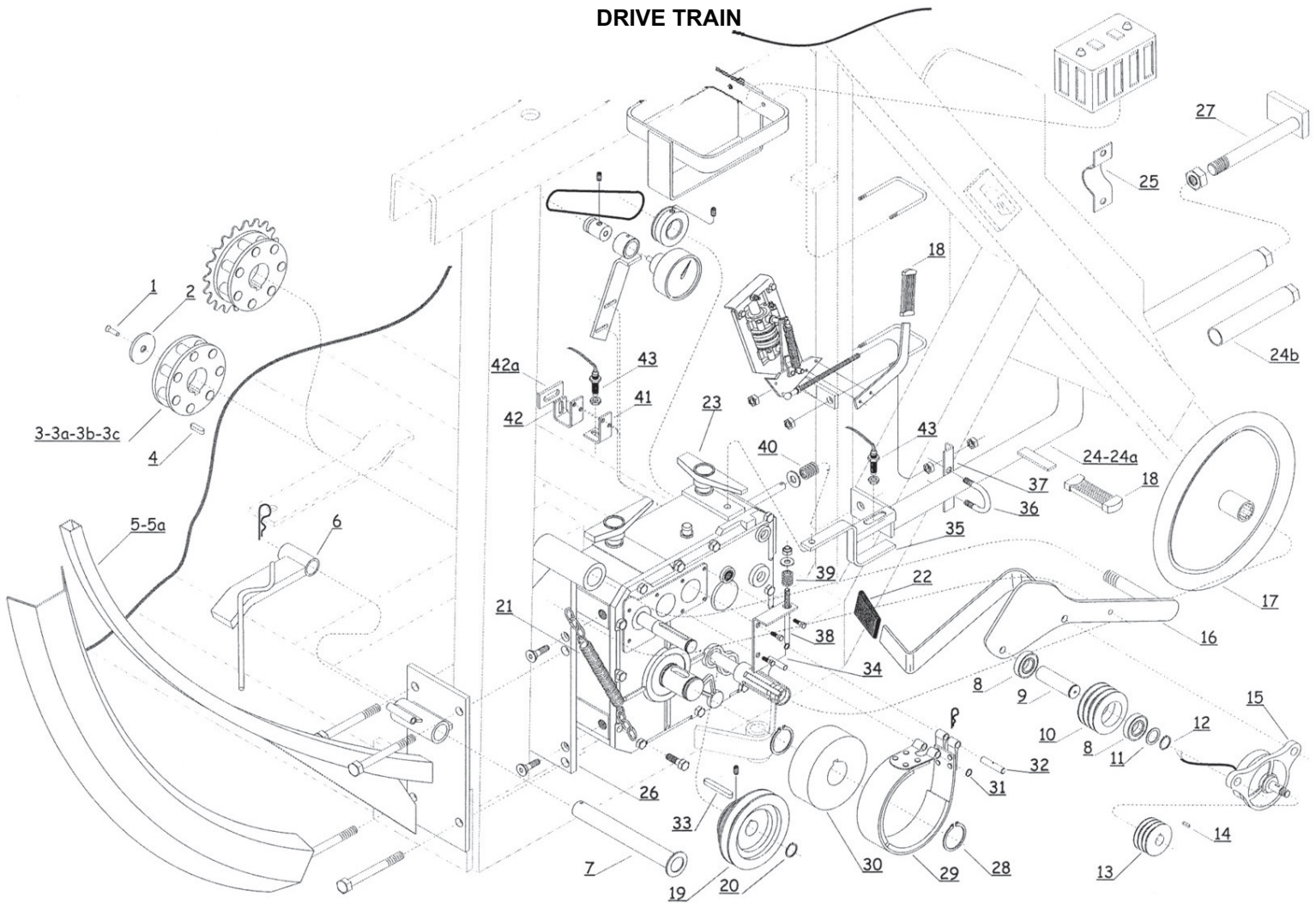

23	50201901	GEARBOX, BIMA GI10 - AR4/5/6/7		1
24	02211275	ROD, STOP LONG FOR BIMA (AR4-5)		1
24a	02211276	ROD, STOP LONG FOR BIMA (AR6-7)		1
24b	02214662	EXTENTION FOR AUTO - ST6/7		1
25	02000164	RETAINER		1
26	02214390	PLATE, ADAPTER BIMA - AR4/5/6/7		1
27	02218360	REGULATION SCREW		1
28	02205340	SNAP RING E35		2
29	02214350	BAND, BRAKE BIMA - AR4/5/6/7		1
30	02214340	DRUM, BRAKE BIMA - AR4/5/6/7		1
31	02205790	SNAP RING E10		1
32	02216380	PIN 9X40		1
33	02205510	KEY 6 X 50		1
34	02218370	BRAKE PLATE B600		1
35	02214290	GUIDE, ROD BIMA - AR4/5/6/7		1
36	02206650	U-BOLT 1" M6		1
37	02218380	DISTRIBOR GUIDE PLATE		1
38	02214380	ROD, BRAKE BIMA - AR4/5/6/7		1
39	02216400	SPRING C98		1
40	02218390	SPRING B600		1
41	02218400	DOSIDIS SENCOR SUPPORT		1
42	02218401	EASYDIS SENCOR SUPPORT PART 1		1
42a	02218402	EASYDIS SENCOR SUPPORT PART 2		1
43	02213730	SENSOR, CRUISE CONTROL		1-2

DRIVE TRAIN

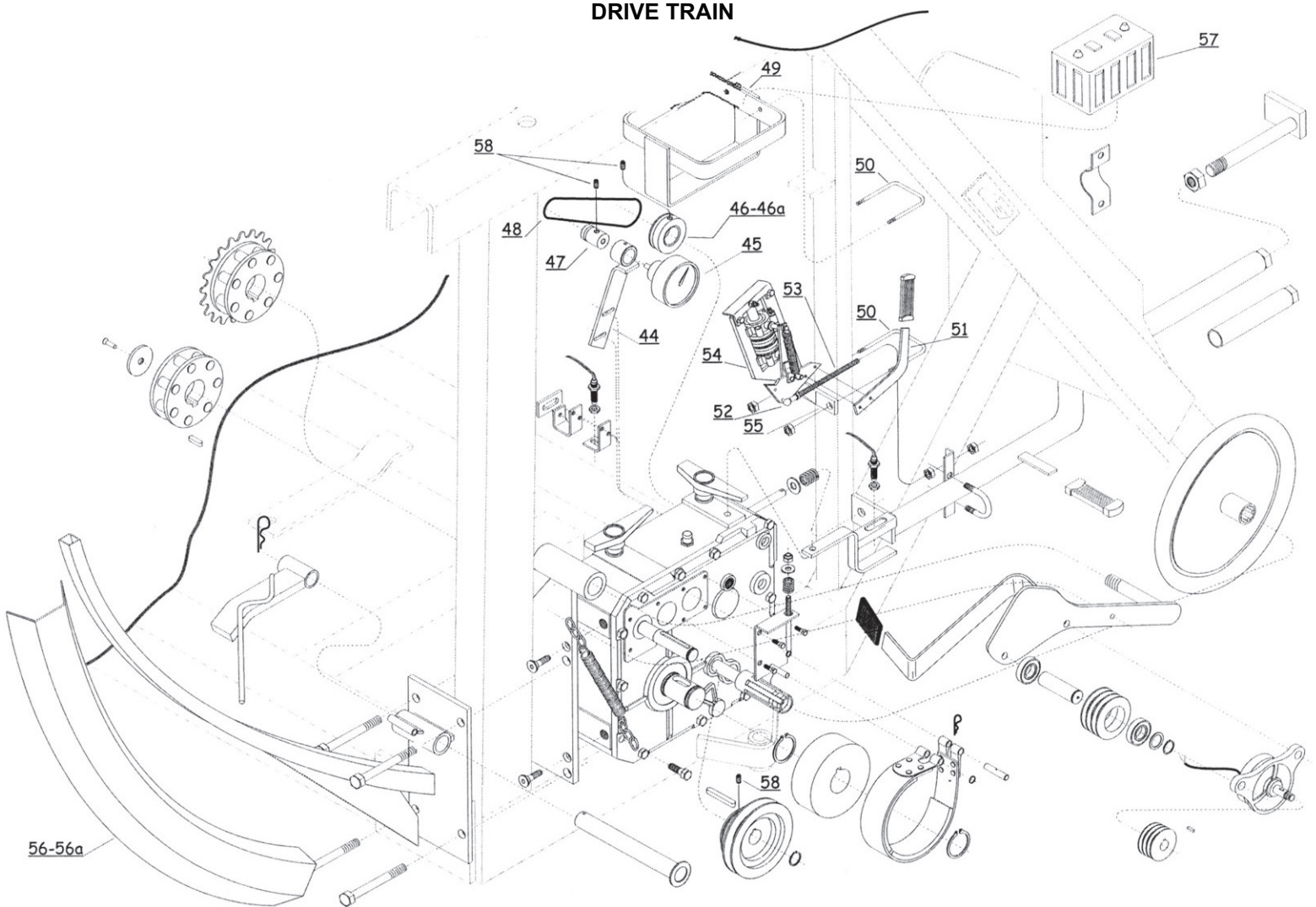

44	02214310	TACH SUPPORT		1
45	02201200	TACHOMETER ASM,0-400 FT/HR A SERIES		1
46	02214320	PULLEY, TACH BIMA - AR4/5/6		1
46a	02214451	TACH PULLEY (AR7)		1
47	02201190	PULLEY, GREEN TACH .788		1
48	02203663	BELT, TACH, DIA 3.5MM X 580MM		1
49	02211380	BATTERY SUPPORT		1
50	02214100	U-BOLT, M10		1
51	02211420	DISTRIBUTOR LEVER		1
52	02203410	ROD END		1
53	02218420	THREADED ROD		1
54	02211390	DISTRIBUTOR FOR SHUT OFF VALVE		1
54a	02211391	DISTRIBUTOR FOR SHUT DOWN VALVE		1
55	02211410	DISTRIBUTOR MT.		1
56	02214770	SHIELD, BLANK FOR AR4 AND AR5		1
56a	02214771	SHIELD, BLANK FOR AR6 AND AR7		1
57	02218430	BATTERY		1
58	55070050	SET SCREW 6-1.00 X 8MM LONG		3

Turbine Drive Bima Gearbox

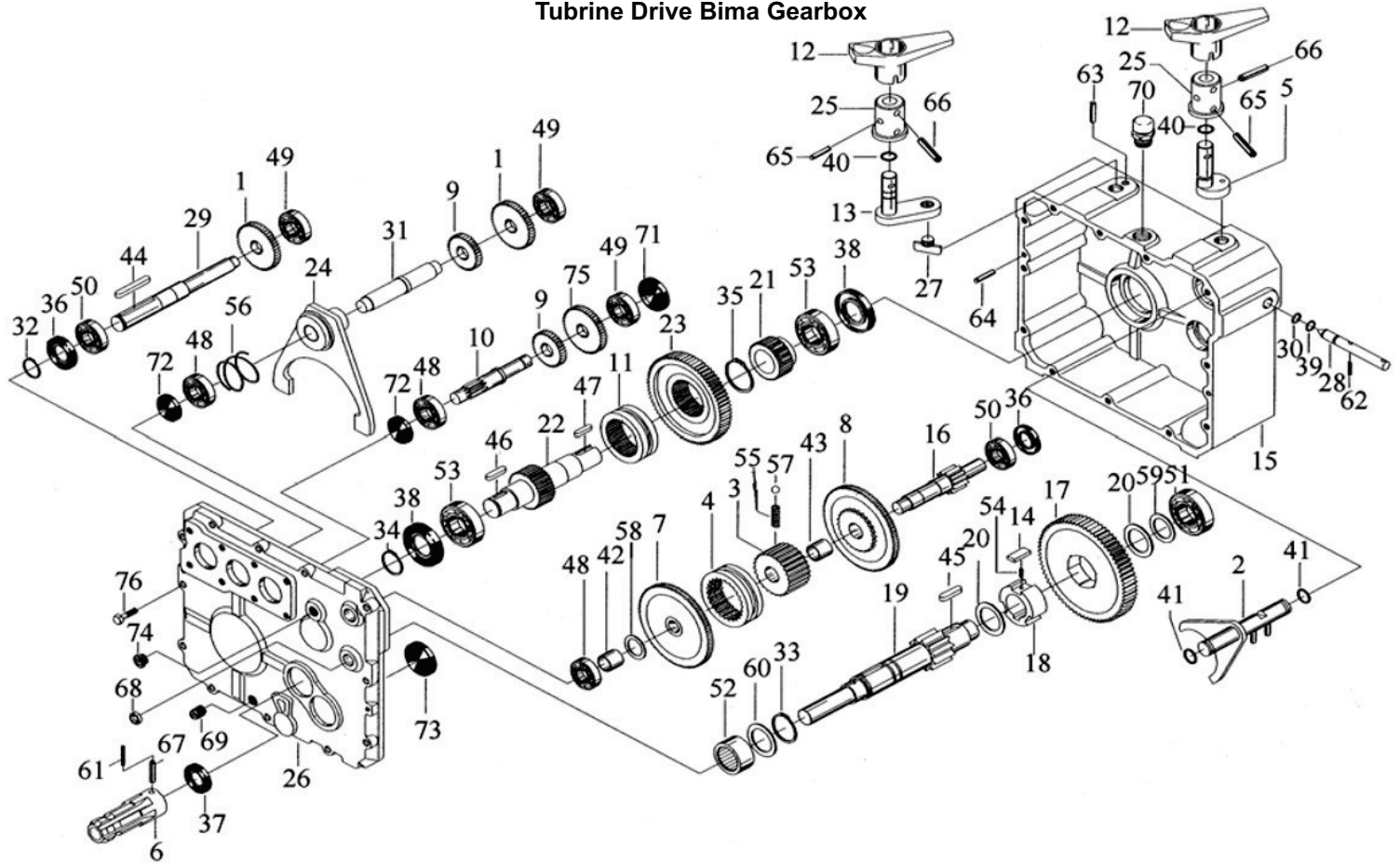

Item	Part Number	Description	Qty.
1	02215550	GEAR 2007.038.442	1
2	02215560	LEVER 2008.011.098	1
3	02215570	HUB 2008.032.042	1
4	02215580	HUB 2008.039.076	1
5	02215590	LEVER 2008.041.098	1
6	02215600	SLEEVE 2008.055.041	1
7	02215610	GEAR 2008.068.426	1
8	02215620	GEAR 2008.069.426	1
9	02215630	GEAR 2008.070.442	1
10	02215640	SHAFT 2008.073.542	1
11	02215650	HUB 2018.010.077	1
12	02215660	LEVER 2022.005.032	1
13	02215670	LEVER 2022.006.098	1
14	02215680	DOG 2047.050.099	1
15	02216590	HOUSING 2083.022.101	1
16	02215700	SHAFT 2053.027.542	1
17	02215710	GEAR 2083.028.426	2
18	02215720	HUB 2083.030.442	1
19	02215730	SHAFT 2083.031.542	1
20	02215740	WASHER 2083.032.061	1
21	02215750	HUB 2083.033.042	1
22	02215760	SHAFT 2083.034.542	1
23	02215770	GEAR 2083.035.426	1
24	02215780	LEVER 2083.037.098	1
25	02215790	HUB 2083.038.041	1
26	02215800	COVER 2083.040.201	1
27	02215810	PAD 2083.041.042	1

Turbine Drive Bima Gearbox

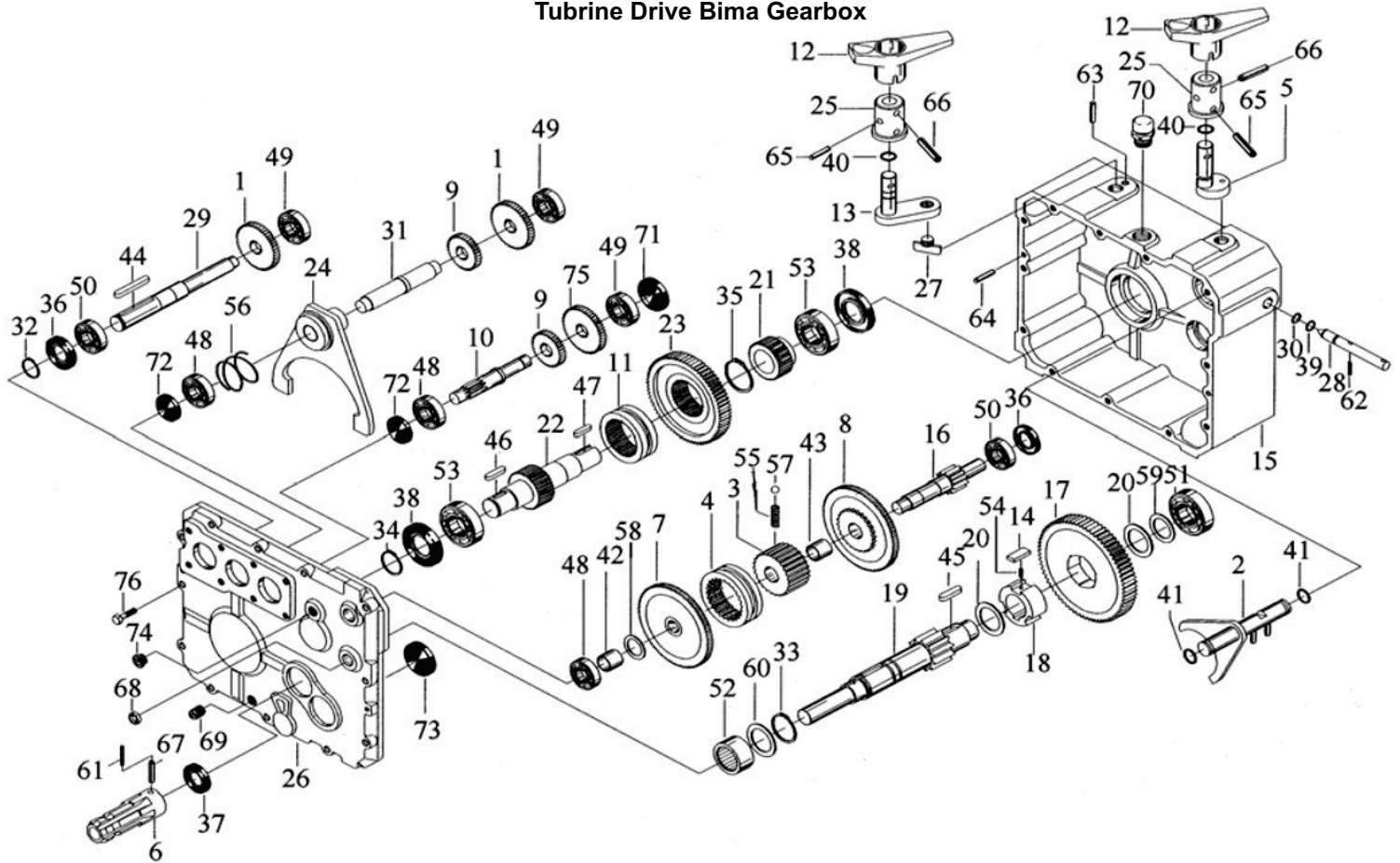

28	02215820	PIN 2083.043.041		1
29	02215831	SHAFT 2083.023.541		1
30	02215840	SNAP RING, D14E 8001.139.000		1
31	02215833	SHAFT, 2083.026.542		1
32	02201680	SNAP RING, D20E 8025.209.000		1
33	02205341	SNAP RING, D30E 8025.302.000		1
34	02205340	SNAP RING D35E 8025.336.000		1
35	02215870	SNAP RING D80E 8025.590.000		1
36	02215880	OIL SEAL 20 X 35 X 6		1
37	50406970	OIL SEAL 30 X 40 X 7		1
38	02215890	OIL SEAL 40 X 62 X 7		1
39	02215900	OIL SEAL CR 109		1
40	02215910	OIL SEAL CR 3043		1
41	02215920	OIL SEAL CR 3050		1
42	02215930	SLEEVE 18X 20 X 15 8100.222.000		1
43	02215940	SLEEVE 20 X 23 X 15 8200.226.000		1
44	02215950	KEY 6 X 6 X 50 8125.215.000		1
45	02207880	KEY 8 X 7 X 25 8125.241.001		1
46	02215960	KEY 10 X 8 X 35 8125.312.000		1
47	02215970	KEY 10 X 8 X 50 8125.324.000		1
48	02215980	BEARING 6302 8200.128.000		1
49	02215990	BEARING 6202 8200.136.000		1
50	02219170	BEARING 6004 8200.164.000		1
51	02216010	BEARING 6205 820.192.000		1
52	02216020	BEARING HK3012 820.208.000		1
53	02216030	BEARING 6208 8200.264.000		1
54	02216040	SPRING 8375.050.000		1

Turbine Drive Bima Gearbox

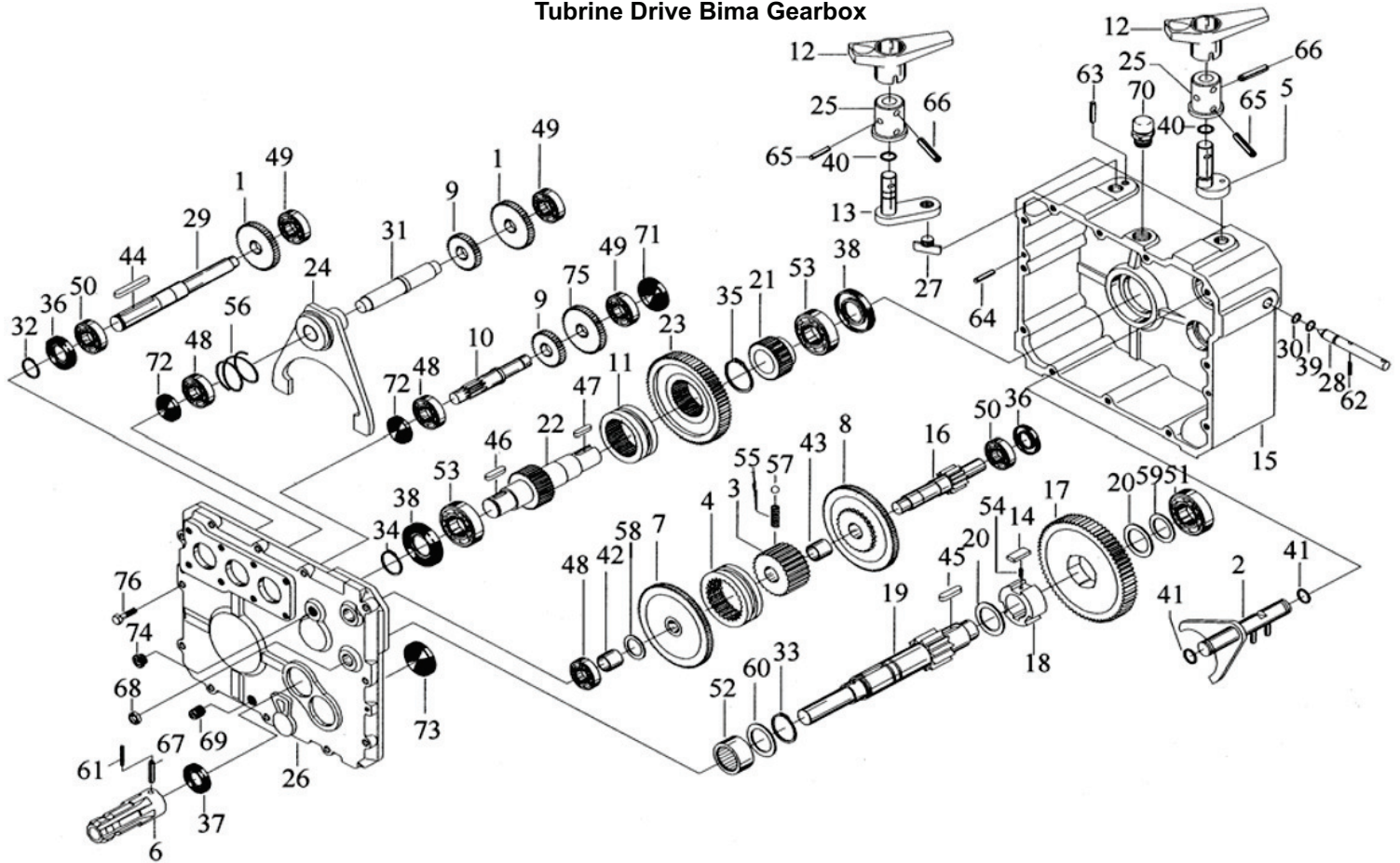

55	02216050	SPRING 8375.080.000		1
56	02216060	SPRING 8375.690.000		1
57	02216070	BALL 8525.152.000		1
58	02216080	SLEEVE 15.2 X 24.9 X 0.8 8550.233.000		1
59	02216090	SLEEVE 25 X 35 X 1 8550.326.000		1
60	02216100	SLEEVE 30.2 X 39.8 X 1 8550.366.000		1
61	02216110	PIN 3.5 X 40 ISO8752 8575.160.000		1
62	02216120	PIN 5 X 24 ISO 8752 8575.229.000		1
63	02216130	PIN 5 X 16 UNI 1707 8575.270.000		1
64	02216140	PIN 6 X 20 UNI 1707 8575.275.000		1
65	02216150	PIN 6 X 30 ISO 8752 8575.284.000		1
66	02216160	PIN 6 X 36 XISO 8752 8575.289.000		1
67	02216170	PIN 6 X 40 ISO 8752 8575.291.000		1
68	02216180	PLUG D75 8600.120.000		1
69	02216190	PLUG 3/8" GAS 8600.144.000		1
70	02216200	PLUG 1/2" GAS 8600.184.000		1
71	02216210	PLUG RCA 22 X 7 8600.215.000		1
72	02216220	PLUG RCA 35 X 8 8600.390.000		1
73	02216230	PLUG RCA 40 X 7 8600.438.000		1
74	02216240	PLUG 3/8" GAS 8625.136.000		1
75	02215552	GEAR 2027.006.442		1
76	02216260	SCREW M 8 X 30 UNI 5739 8675.189.080		1

ENGINE DRIVE

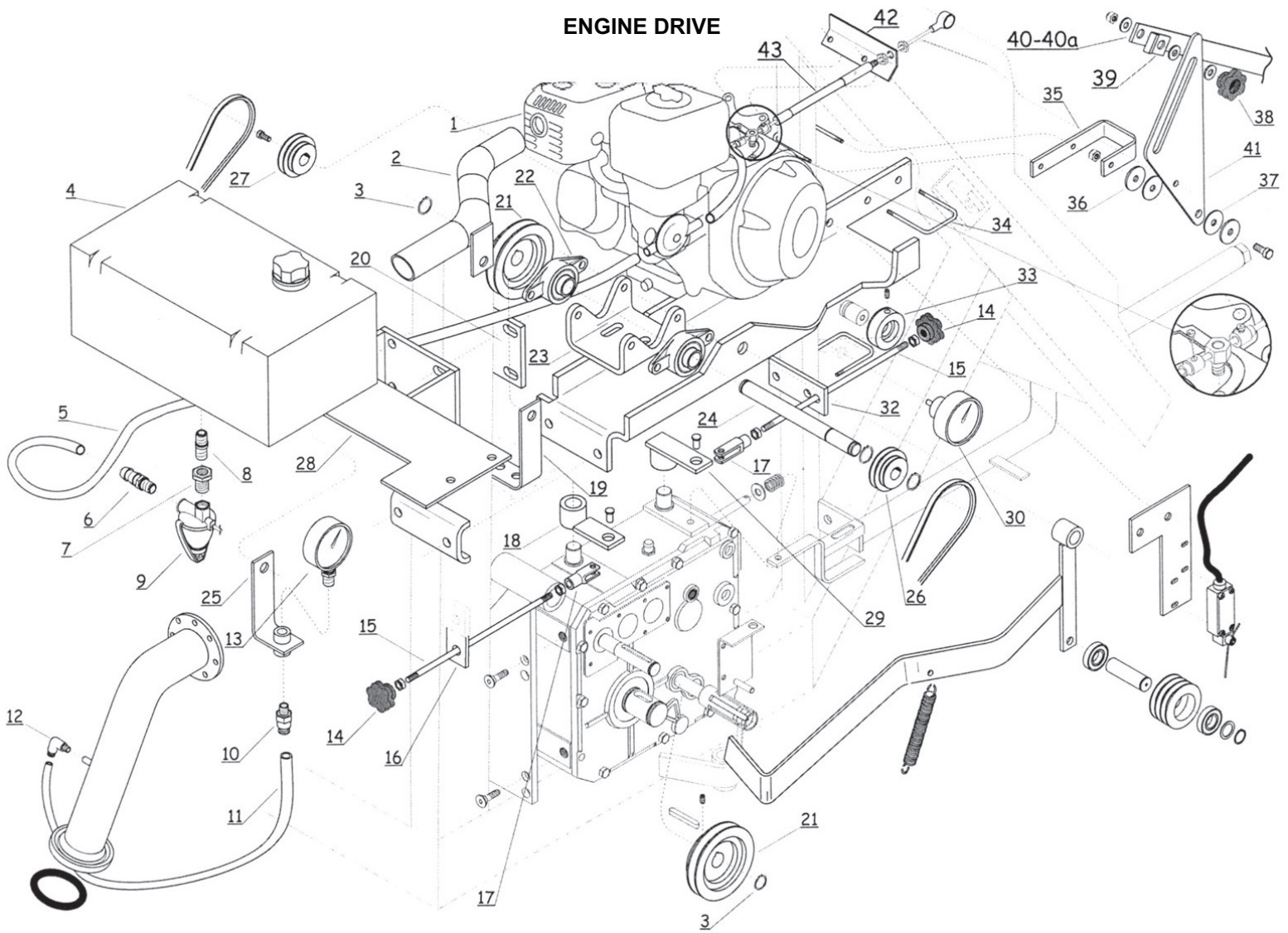

Item	Part Number	Description	Qty.
1	58407017	ENGINE,HONDA 4HP KEYED SH	1
2	02216720	EXHAUST PIPE ST7	1
2a	02216721	EXHAUST PIPE ST4	1
3	02201680	RETAINING RING E20	4
4	50207100	TANK, GAS 6 GAL PLASTIC W/FITTING	1
5	58406951	HOSE,GAS 1/4X27/64	ft. 3.3
6	52548760	BARB,HOSE BR 1/8 NPT X 1/4	1
7	52547842	BSHNG, RDCNG BR 1/4X1/8	1
8	52508981	NPPL,CLOSE BR 1/8 SCHD. 40	1
9	27749190	FILTER,GLASS BOWL FUEL	1
10	52549153	FTG,TB STG 1/4MNPTX5/16TB	1
11	25249392	TUBE,SYNFLEX 5/16 OD	1
12	52549152	FTG,TB 90 1/4NNPTX5/16TUB	1
13	58606750	GAUGE, PRESS 0-300	1
14	02203910	HAND WHEEL	2
15	02218440	DISENGAGE/SPEED ROD	1
16	02216910	PLATE, SHIFTER MT.	1
17	02218450	CLEVIS ROD END	2
18	02218460	DISENGAGE LEVER	1
19	02218470	EXHAUST PIPE SUPPORT ST7	1
19A	02218471	EXHAUST PIPE SUPPORT ST4	1
20	02218480	PLATE, CLAMP GAS TANK MT.	1
21a	02216730	PLLY, 2 STEP, 147 & 125MM 20MM BORE	2
21b	02216731	PLLY,TAPER, 147 & 125MM 20MM BORE	2

ENGINE DRIVE

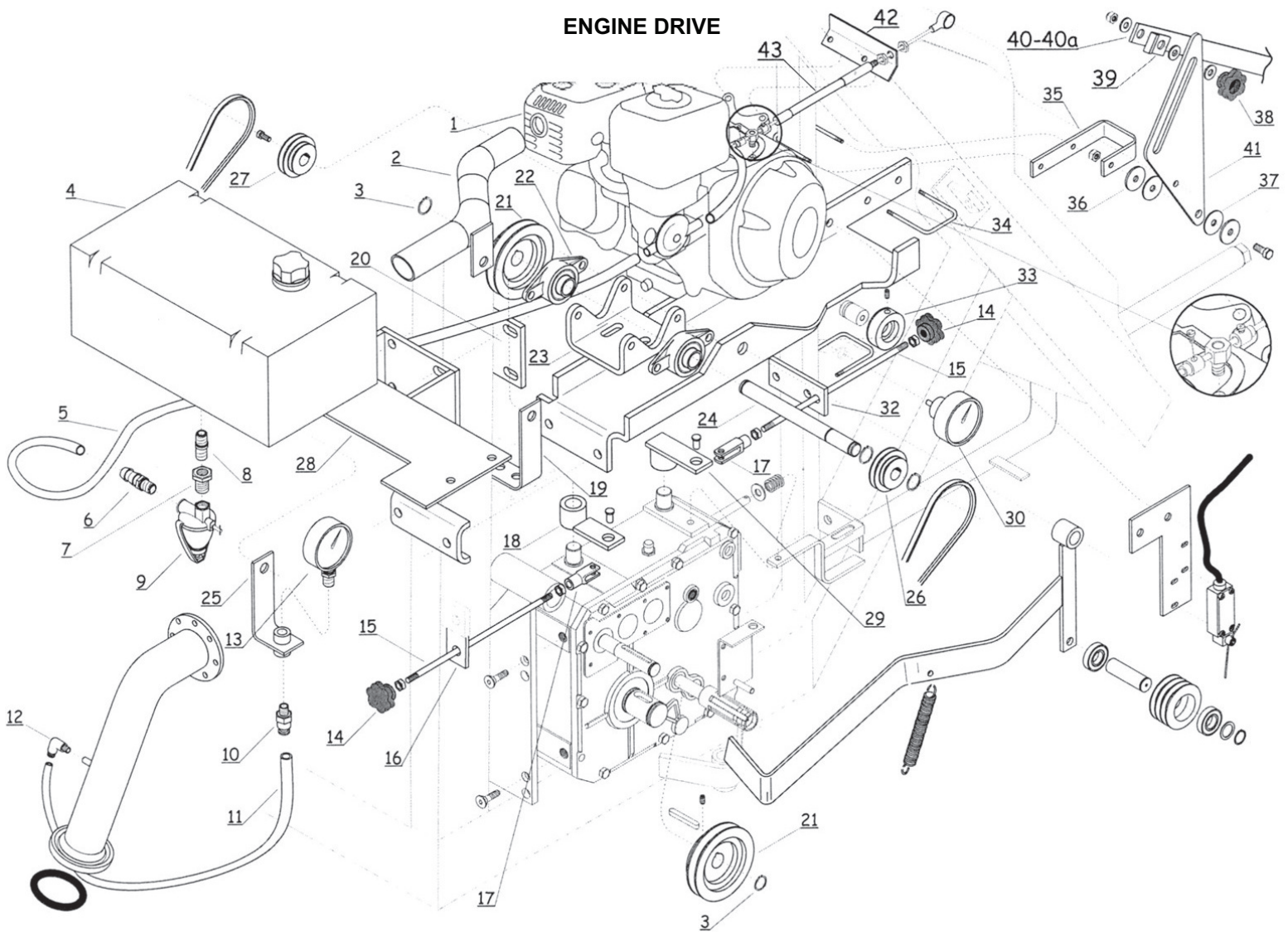

22	50101460	BEARING,FLANGE (20MM)		2
23	02216560	BRACKET, JACKSHAFT BEARING-AG400K+		1
24	02216570	SHAFT, JACK - IRR ENGINE -AG4/5/6/7 (<u>Straight Shaft</u>)		1
24a	02216571	SHAFT, JACK - IRR ENGINE -AG4/5/6/7 (<u>Tapered Shaft</u>) (not shown)		1
25	02216840	GAUGE MT. ENGINE DRIVE ST4-5-6-7		1
26a	02216580	PLLY,75MM,53MM 2STEP W/SETSCR 20MM (<u>Straight Shaft</u>)		1
26b	02216581	PLLY,75MM,53MM 2STEP W/SETSCR 20MM (<u>Tapered Shaft</u>) (not shown)		1
27	02216590	PLLY,53MM,75MM 2STEP W/SETSCR 19MM (<u>Straight Shaft</u>)		1
27a	02216591	PLLY,53MM,75MM 2STEP W/SETSCR 19MM (<u>Tapered Shaft</u>) (not shown)		1
26-27a		4mm Woodruff Key (not shown)		2
28	02216820	TANK MT. ENGINE ST4-5-6-7		1
29	02218490	LEVER GEARBOX SPEED CHANGE		1
30	02201200	TACHOMETER ASM,0-400 FT/HR A SERIES		1
32	02218500	SPEED ROD SUPPORT PLATE		1
33	02218510	TACH FIX		1
34	02214100	U-BOLT, M10		3
35	02218520	COMPENSATION TRIANGLE SUPPORT		1
36	02218530	WASHER 8MM X 50MMX 5MM		2
37	02099049	WASHER		2
38	02218540	WHAND WHEEL 60 X 8MM		1
39	02218550	COMPENSATION PLAT GUIDE ROD		1
40	02218031	HONDA ENGINE REGULATION ROD ST4-5		1
40a	02218032	HONDA ENGINE REGULATION ROD ST6-7		1
41	02218560	COMPENSATION TRIANGLE		1
42	02216790	CABLE MT. ENGINE DRIVE		1
43	02216900	CABLE 7MM X 190MM M8		1

ENGINE DRIVE

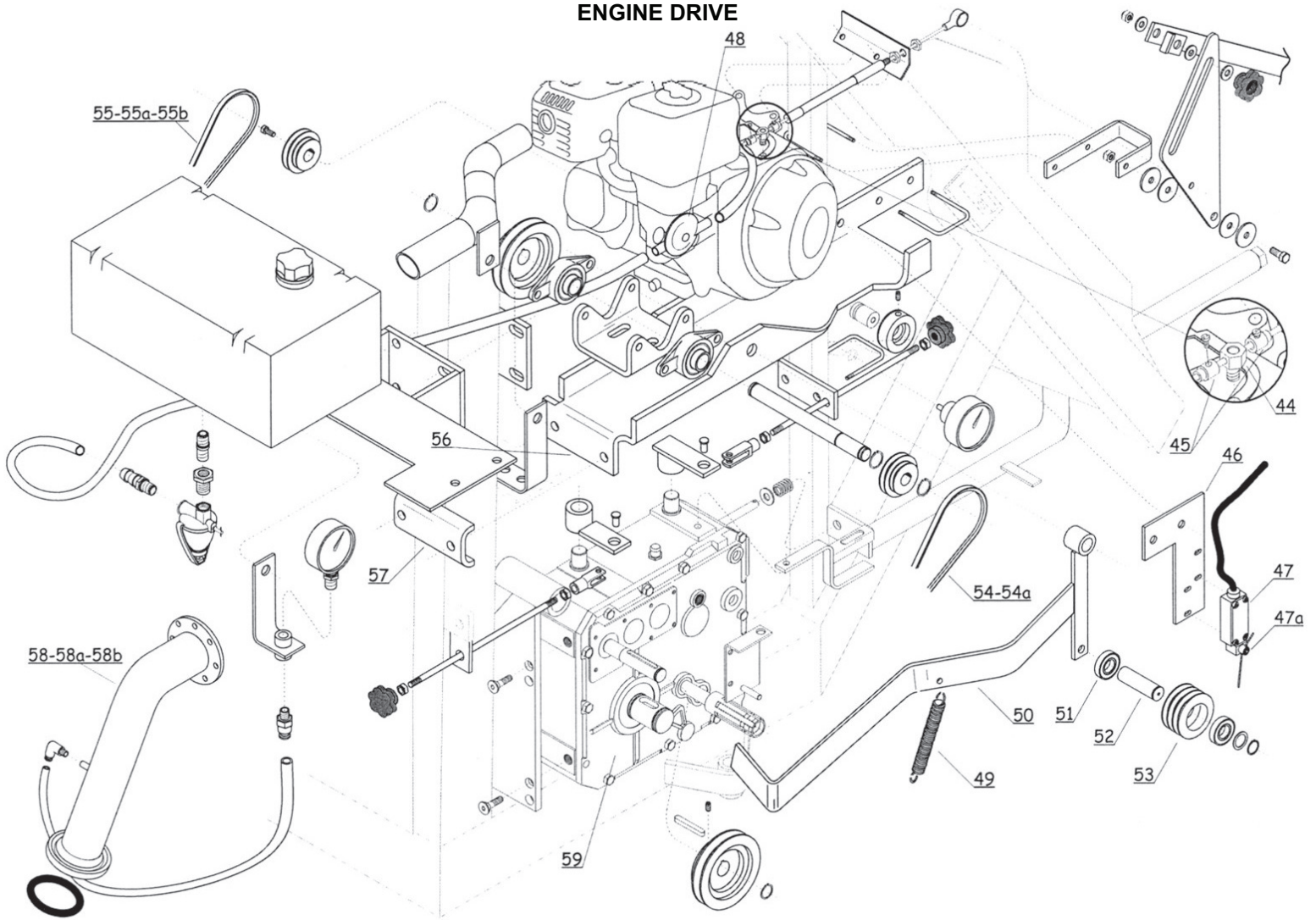

44	02218570	ACCELERATOR SCREW		1
45	02218571	CABLE STOP		2
46	02216750	SWITCH MT.		1
47	02216760	SWITCH		1
47a	02216761	SENSOR HEAD		1
48	50404620	FUEL FILTER 1/4" CLEAR WITH CLAMPS		1
49	02203180	SPRING BELT TIGHTENER		1
50	02216630	BELT TIGHTENER		1
51	02203440	BEARING,6005-2RS		2
52	02206530	SHAFT,BELT IDLER		1
53	02206540	PULLEY IDLER 3 GROOVE		1
54	02206660	BELT AX 35 ST4-5		1
54a	59904282	BELT AX 38 ST6-7		1
55	59904260	BELT AX 33 ST4		1
55a	59904271	BELT AX 31 ST5-6		1
55b	59904270	BELT AX 32 ST7		1
56	02218580	ENGINE SUPPORT		1
57	02218581	ENGINE SUPPORT CLAMP		1
58	02216780	ELBOW, ENGINE ST6-7		1
58a	02216781	ELBOW, ENGINE ST4		1
58b	02216782	ELBOW, ENGINE ST5		1
59	50201902	GEARBOX, BIMA GI10 - AG4/5/6/7		1

ENGINE DRIVE Bima Gearbox

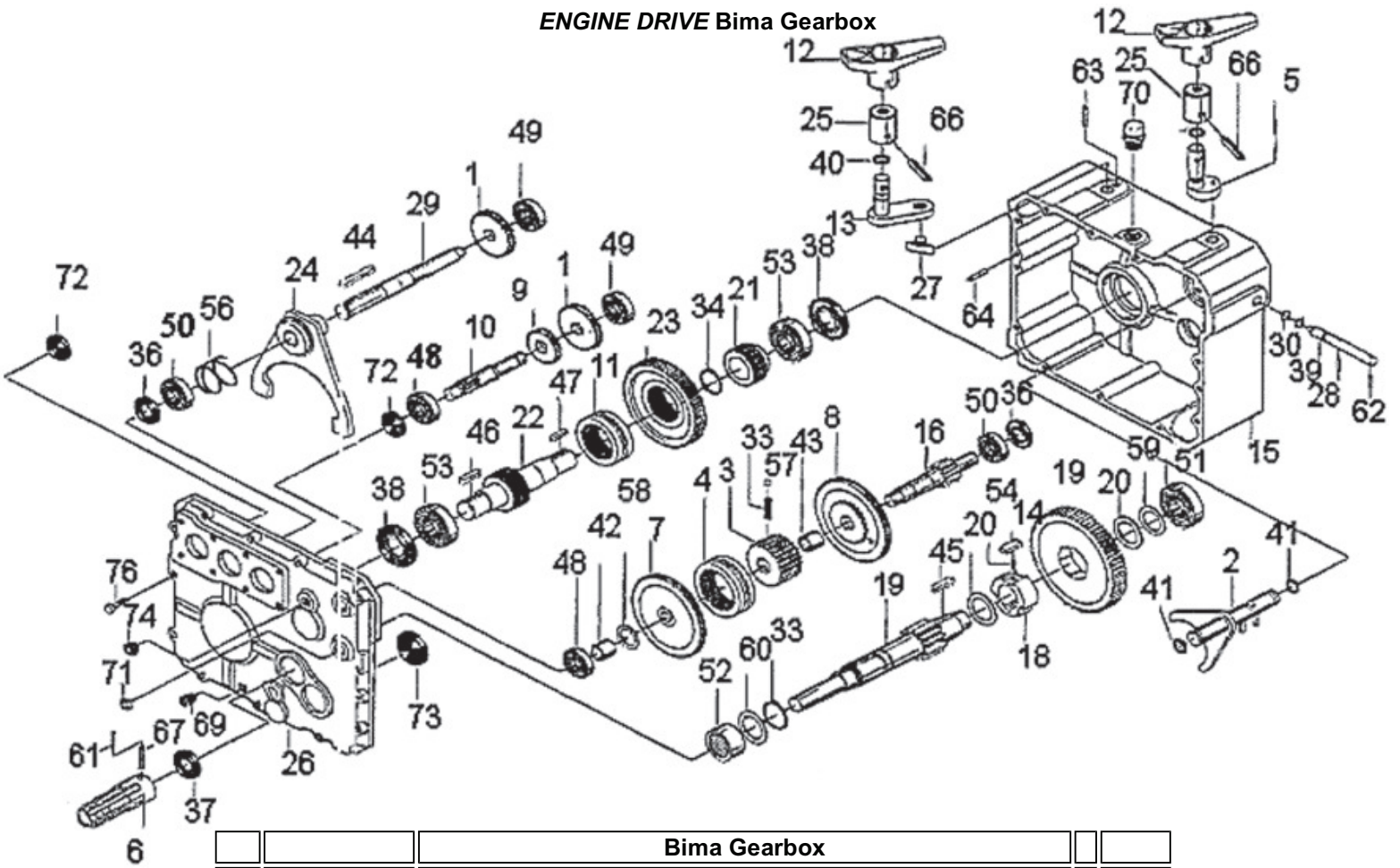

Bima Gearbox			
No.	Part Number	Description	Qty.
1	02215550	GEAR 2007.038.442	1
2	02215560	LEVER 2008.011.098	1
3	02215570	HUB 2008.032.042	1
4	02215580	HUB 2008.039.076	1
5	02215590	LEVER 2008.041.??8	1
6	02215600	SLEEVE 2008.055.041	1
7	02215610	GEAR 2008.068.426	1
8	02215620	GEAR 2008.069.426	1
9	02215630	GEAR 2008.070.442	1
10	02215640	SHAFT 2008.073.542	1
11	02215650	HUB 2018.010.077	1
12	02215660	LEVER 2022.005.032	1
13	02215670	LEVER 2022.006.098	1
14	02215680	DOG 2047.050.099	1
15	02215690	HOUSING 2083.022.101	1
16	02215700	SHAFT 2053.027.542	1
17	02215710	GEAR 2083.028.426	2
18	02215720	HUB 2083.030.442	1
19	02215730	SHAFT 2083.031.542	1
20	02215740	WASHER 2083.032.061	1
21	02215750	HUB 2083.033.042	1
22	02215760	SHAFT 2083.034.542	1
23	02215770	GEAR 2083.035.426	1

ENGINE DRIVE Bima Gearbox

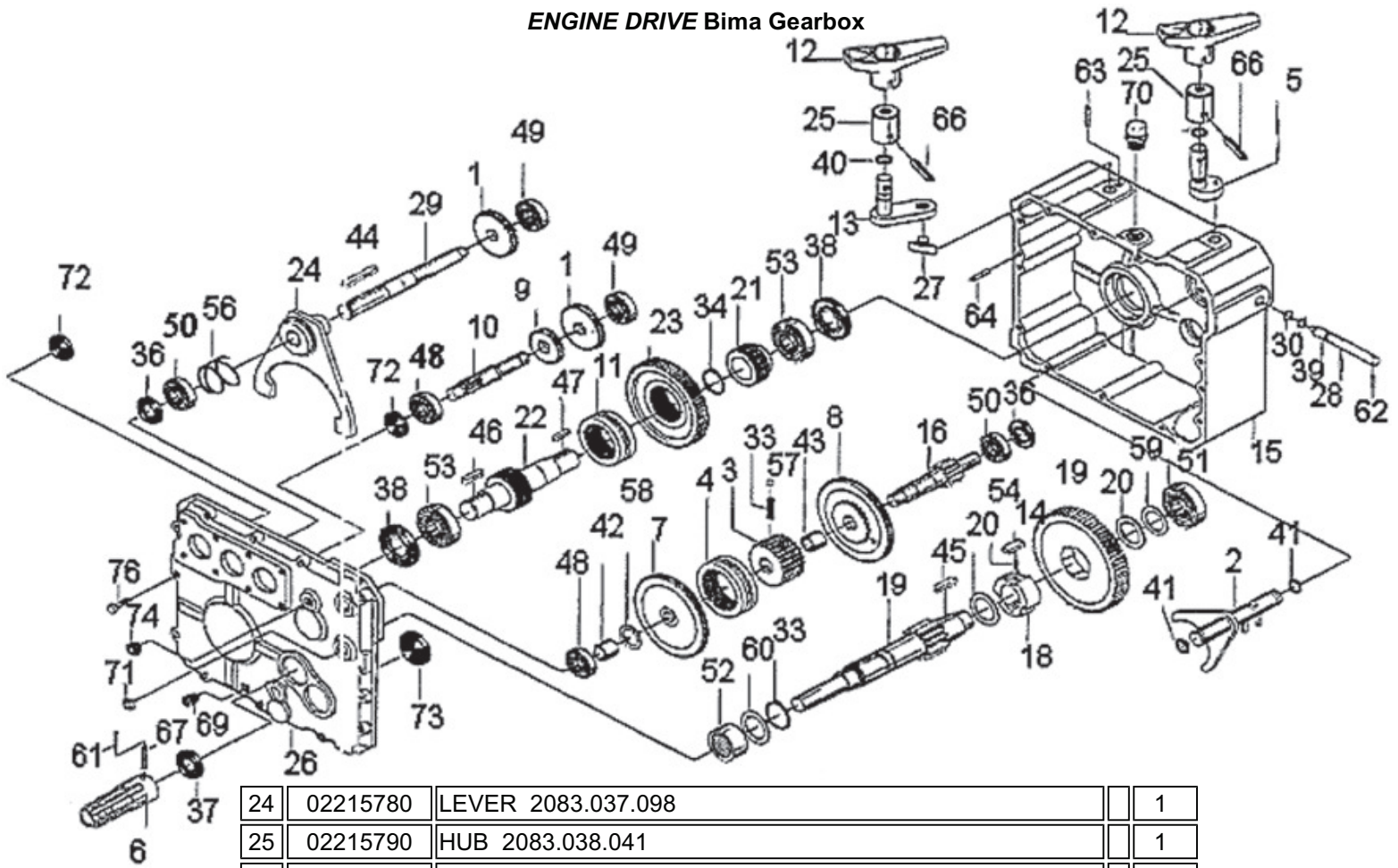

24	02215780	LEVER 2083.037.098		1
25	02215790	HUB 2083.038.041		1
26	02215800	COVER 2083.040.201		1
27	02215810	PAD 2083.041.042		1
28	02215820	PIN 2083.043.041		1
29	02215830	SHAFT 2083.056.541		1
30	02215840	SNAP RING, D14E 8001.139.000		1
31	02215860	SNAP RING, D18E 8025.185.000		1
32	02201680	SNAP RING, D20E 8025.209.000		1
33	02205341	SNAP RING, D30E 8025.302.000		1
34	02205340	SNAP RING D35E 8025.336.000		1
35	02215870	SNAP RING D80E 8025.590.000		1
36	02215880	OIL SEAL 20 X 35 X 6		1
37	50406970	OIL SEAL 30 X 40 X 7		1
38	02215890	OIL SEAL 40 X 62 X 7		1
39	02215900	OIL SEAL CR 109		1
40	02215910	OIL SEAL CR 3043		1
41	02215920	OIL SEAL CR 3050		1
42	02215930	SLEEVE 18X 20 X 15 8100.222.000		1
43	02215940	SLEEVE 20 X 23 X 15 8200.226.000		1
44	02215950	KEY 6 X 6 X 50 8125.215.000		1
45	02207880	KEY 8 X 7 X 25 8125.241.001		1
46	02215960	KEY 10 X 8 X 35 8125.312.000		1
47	02215970	KEY 10 X 8 X 50 8125.324.000		1

ENGINE DRIVE Bima Gearbox

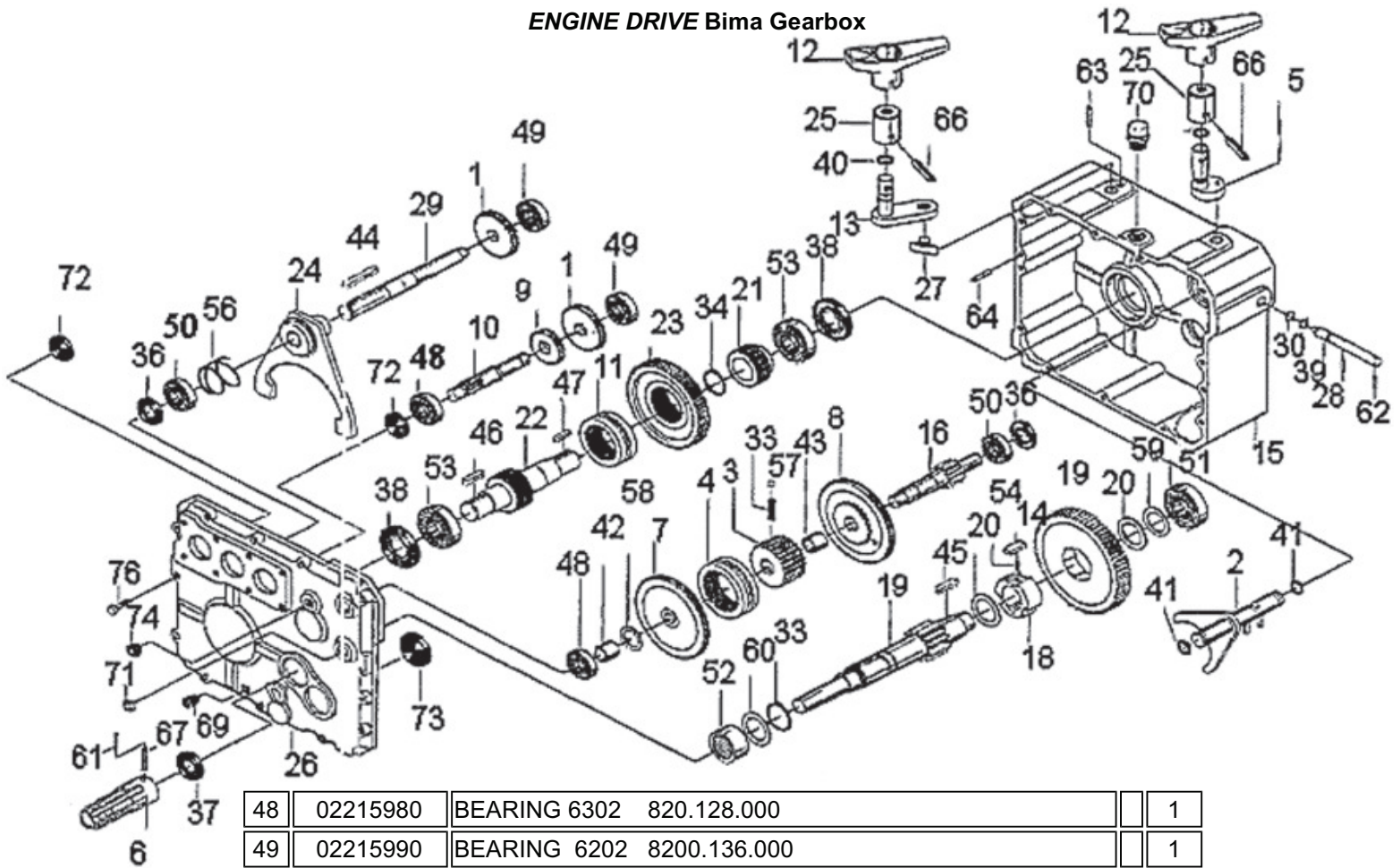

48	02215980	BEARING 6302 820.128.000		1
49	02215990	BEARING 6202 8200.136.000		1
50	02219170	BEARING 6004 8200.164.000		1
51	02216010	BEARING 6205 820.?92.000		1
52	02216020	BEARING HK3012 820.208.000		1
53	02216030	BEARING 6208 8200.264.000		1
54	02216040	SPRING 8375.050.000		1
55	02216050	SPRING 8375.080.000		1
56	02216060	SPRING 8375.690.000		1
57	02216070	BALL 8525.152.000		1
58	02216080	SLEEVE 15.2 X 24.9 X 0.8 8550.233.000		1
59	02216090	SLEEVE 25 X 35 X 1 8550.326.000		1
60	02216100	SLEEVE 30.2 X 39.8 X 1 8550.366.000		1
61	02216110	PIN 3.5 X 40 ISO8752 8575.160.000		1
62	02216120	PIN 5 X 24 ISO 8752 8575.229.000		1
63	02216130	PIN 5 X 16 UNI 1707 8575.270.000		1
64	02216140	PIN 6 X 20 UNI 1707 8575.275.000		1
65	02216150	PIN 6 X 30 ISO 8752 8575.284.000		1
66	02216160	PIN 6 X 36 XISO 8752 8575.289.000		1
67	02216170	PIN 6 X 40 ISO 8752 8575.291.000		1
68	02216180	PLUG D75 8600.120.000		1
69	02216190	PLUG 3/8" GAS 8600.144.000		1
70	02216200	PLUG 1/2" GAS 8600.184.000		1

ENGINE DRIVE Bima Gearbox

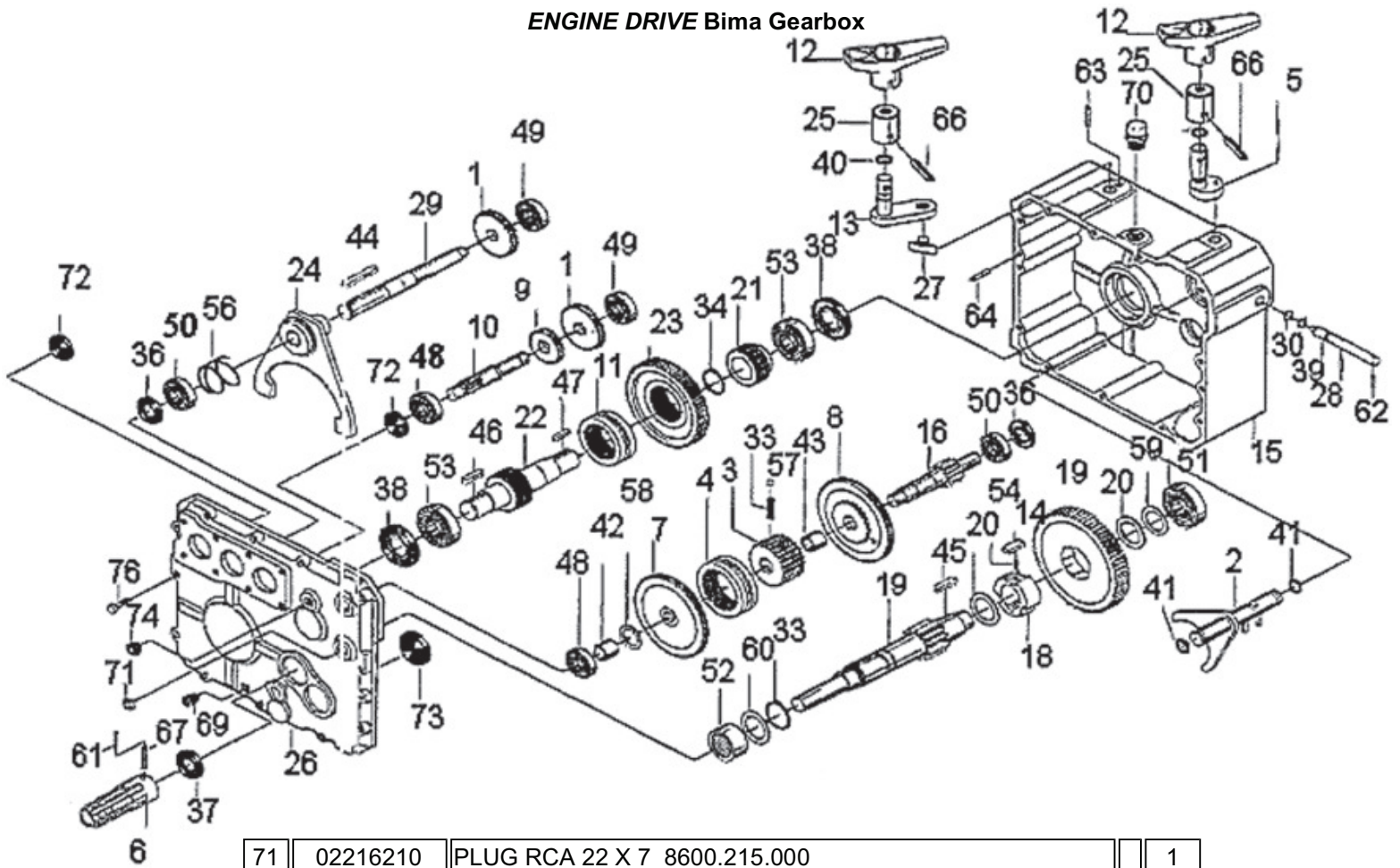

71	02216210	PLUG RCA 22 X 7 8600.215.000	1
72	02216220	PLUG RCA 35 X 8 8600.390.000	1
73	02216230	PLUG RCA 40 X 7 8600.438.000	1
74	02216240	PLUG 3/8" GAS 8625.136.000	1
75	02216250	SCREW M 5 X 16 UN 5931 8675.031.050	1
76	02216260	SCREW M 8 X 30 UNI 5739 8675.189.080	1

Turbine 10/50

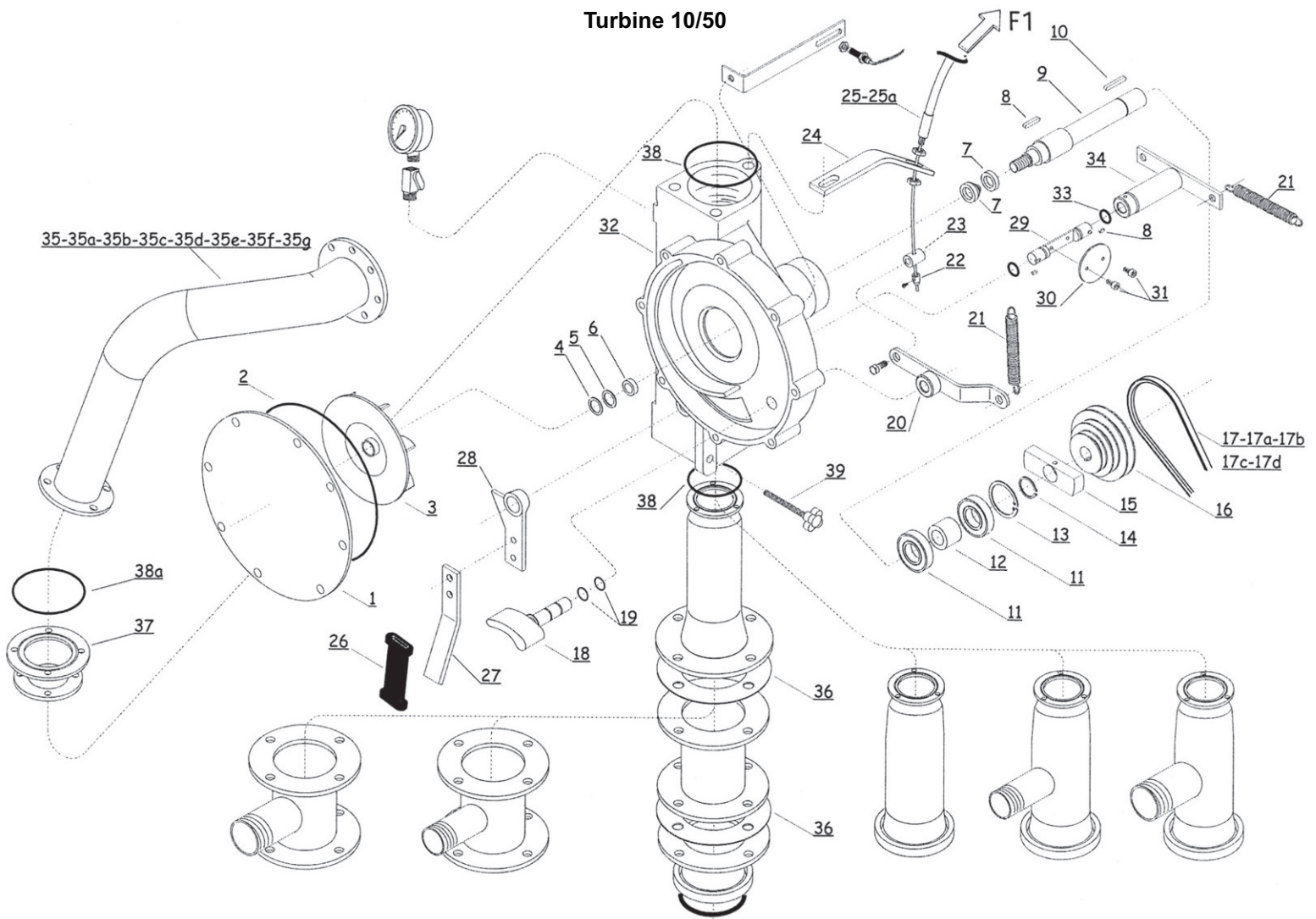

Item	Part Number	Description		
1	02203340	COVER, 10/50 TURBINE		1
2	02203330	O-RING DIA. 203 X 3.53		1
3	02201990	IMPELLER 5.43 X .51VANE H		1
4	02205430	SHIM,MYLLAR 16.2X23.8X.25		
5	02203010	SPACER DIA.25MM X 20MM X 1.5MM		1
6	02203000	SPACER,25MM X 16MM X 7MM		1
7	02205450	SEAL,20 X 6		1
8	02203370	KEY 5 X 10		1
9	02203260	IMPELLER SHAFT		1
10	02205510	KEY 6 X 50		2
11	02201670	BEARING,6204-2RS		1
12	02203250	SPACER, 25MM X 20MM X 10.2MM		1
13	02203240	STOP RING I47		1
14	02201680	RETAINING RING E20		1
15	02218890	COMMAND PLATE SENSOR TURBINE		1
16	02205920	PLY,100MM,75MM,53MM3STEP W/SETSCR		1
17	58408761	BELT, 4L71 OR A69		1
17a	58408762	BELT, 4L72 OR A70		1
17b	02205551	BELT, 4L73 OR A71		1
17c	50201760	BELT, 4L56 OR A54		1
17d	52651902	BELT,A55		1
18	02203320	REGULATOR FLAP		1
19	02203310	O-RING 8.73MM ID X 1.78MM CS		2
20	02211430	CONTROL LEVER FLAP		1
21	02203180	SPRING BELT TIGHTENER		1

Turbine 10/50

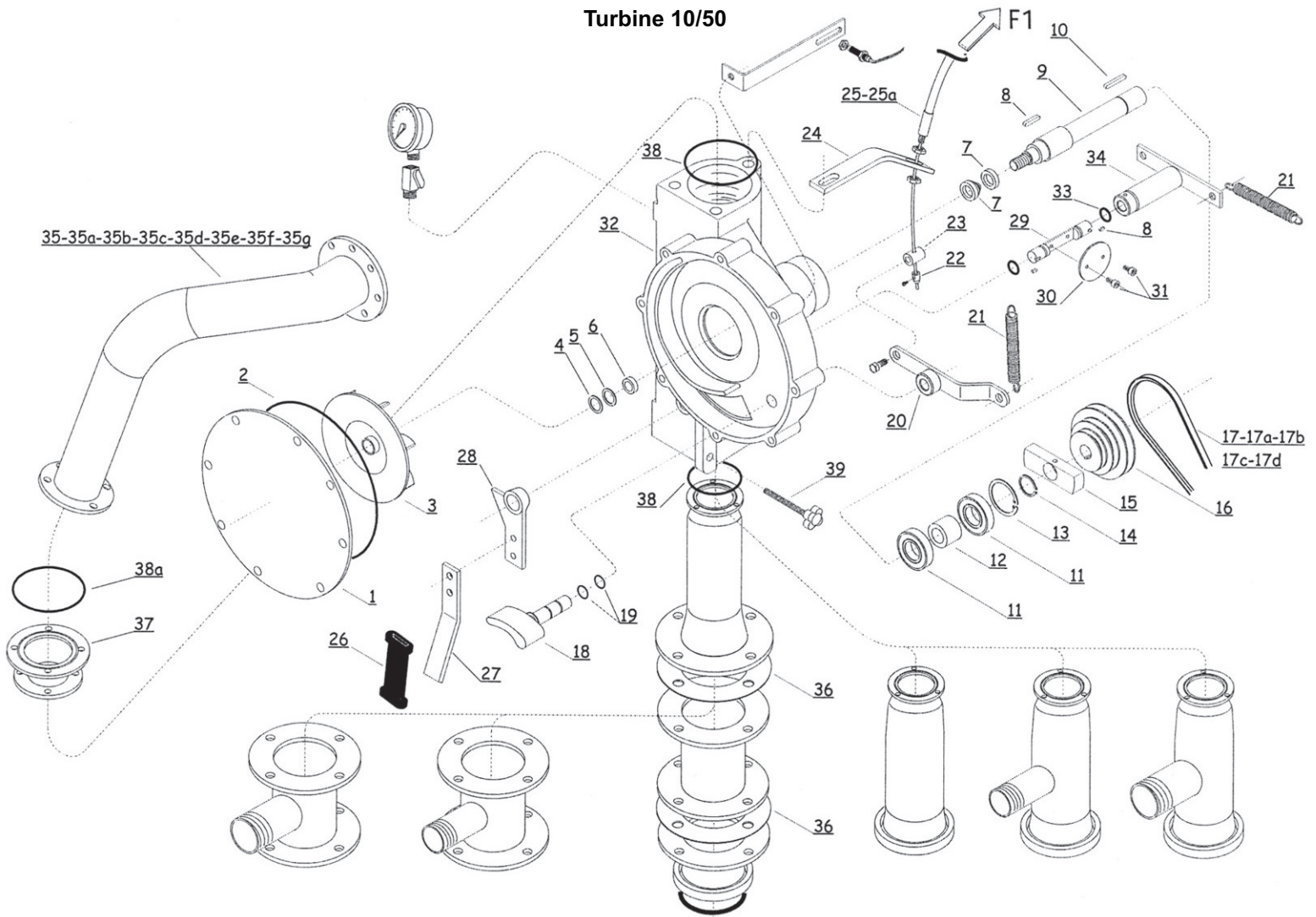

22	02218900	CABLE STOP		1
23	02211450	CABLE ATTACHMENT		1
24	02211460	CABLE MOUNT		1
25	02211830	CABLE FLAP		1
26	02204140	GRIP, TURBINE		1
27	02205570	LEVER,BY-PASS		1
28	02255810	LEVER, BY-PASS - 10/50		1
29	02203071	SHAFT,BYPASS W/O GROOVES		1
30	02203400	DISC. BY-PASS		1
31	02203050	SCREW,6-1MM X 16MM		2
32	02203020	BODY,TURBINE 10/50		1
33	02203060	O-RING DIA. 10.77 X 2.62		2
34	02211480	BY-PASS LEVER		1
35	02211150	ELBW,UPPER (COMER BOX)-ST4		1
35a		ELBW,UPPER (COMER BOX)-ST5		1
35b	02211840	ELBW,UPPER 6"FLNG TO WELD(COMER)AR5		1
35c	02212100	ELBW,UPPER COMER ST6-7		1
35d	02211151	ELBW,UPPER (BIMA BOX)-AR4		1
35e	02211841	LONG ELBW,UPPER 8"FLNG TO WELD(BIMA)-AR5		1
35f		LITTLE ELBW,UPPER 8"FLNG TO WELD(BIMA)-AR5		1
35g	02212101	ELBW,UPPER AR6-7 (BIMA GEARBO		1
36	02217970	GASKET, DN80		1
37	02218920	ELBOW ADAPTOR ST5-ST6		1
38	02203030	O-RING,DIA. 71.54 X 3.53		2
38a	02204840	O-RING 104MM X 3.53MM		1
39	02203910	HAND WHEEL		1

Turbine 10/50

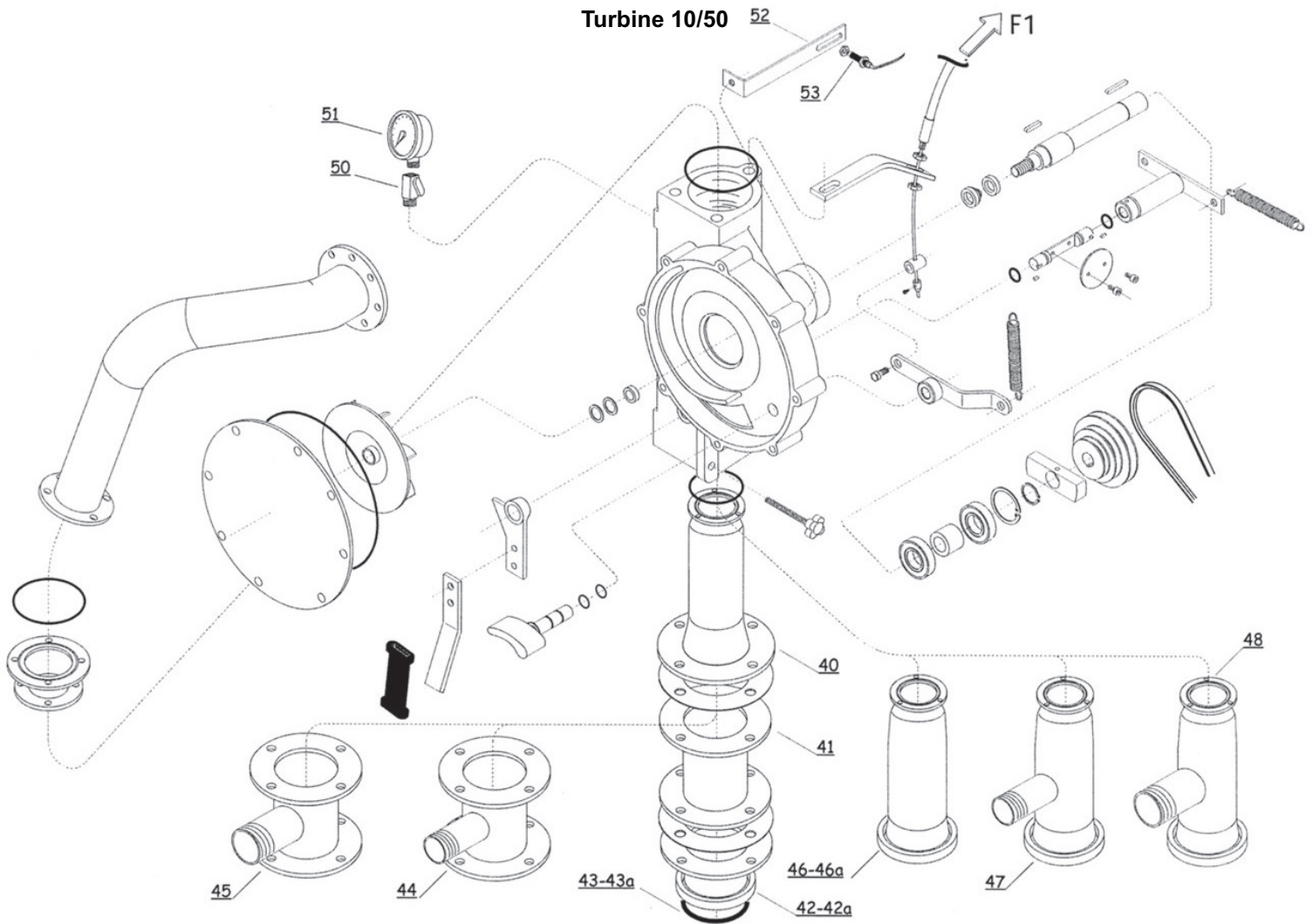

40	02218910	LOWER FEEDING ELBOW FOR VALVE & SUP		1
41	02218930	NIPPLE WITH FLANGE		1
42	02218931	NIPPLE WITH FLANGE AND BAUER 3"1/2		1
42a	02218932	NIPPLE WITH FLANGE AND BAUER 4"		1
43	58800263	SEAL RING 3.5" 5.25ODX.5		1
43A	58800233	SEAL RING 4" 6-3/8 OD X 9/16		1
44g	02218933	NIPPLE WITH FLANGE AND NPPL 1"1/2		1
45	02217991	NIPPLE WITH FLANGE AND NIPPLE 2"1/2		1
46	02218934	NIPPLE WITH BAUER 3"1/2		1
46a	02218935	NIPPLE WITH BAUER 4"		1
47o	02218936	NIPPLE WITH BAUER 3"1/2 NPPL 1"1/2		1
48	02218937	NIPPLE WITH BAUER 4"NPPL 2"1/2		1
50	02218940	GAUGE COCK		1
51	58606750	GAUGE, PRESS 0-300		1
52	02218950	SENSOR SUPPORT		1
53	02213730	SENSOR, CRUISE CONTROL		1

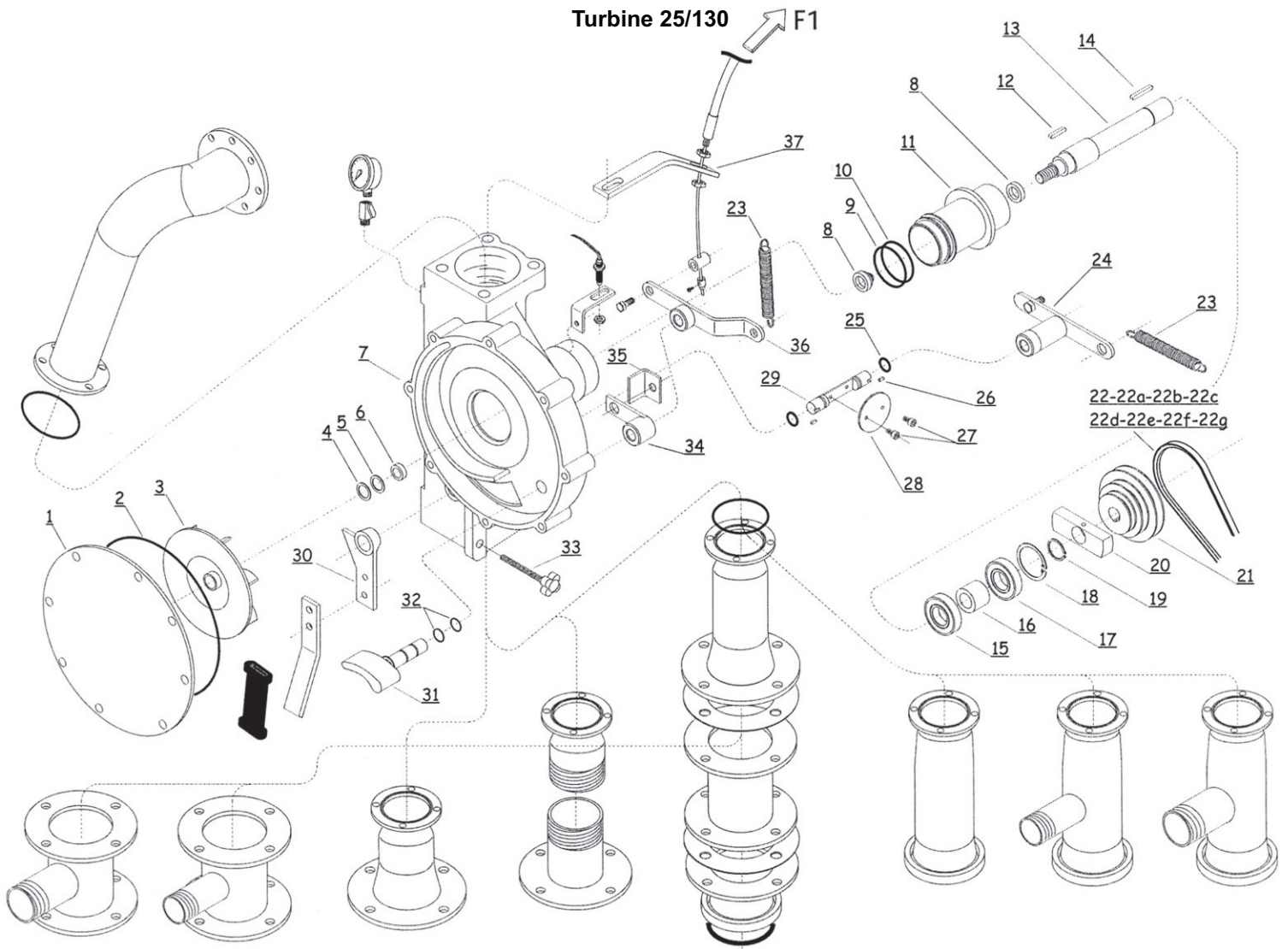

Item	Part Number	Description		1
1	02208340	COVER,IMPELLER		1
2	02205720	O-RING 278.99MM ID X 3.53C/S		1
3	02201993	IMPELLER 6.77ODX.87 VANE		1
3	02201994	IMPELLER 6.77ODX.51 VANE		1
3	02201995	IMPELLER 6.77ODX.24 VANE		1
4	02205430	SHIM,MYLLAR 16.2X23.8X.25		6
5	02203002	SPACER,25MM X 16MM X 15.5MM LONG		
5	02203000	SPACER,25MM X 16MM X 7MM		1
6	02205440	SPACER 25MM X 20MM X 5MM		1
7	02203021	BODY,TURBINE 25/120		1
8	02205450	SEAL,20 X 6		
8a	99070300	KIT, RUNNER OVERHAUL - 25/120 (would recomend customer buy kit in place of seal) This kit includes #9-10-11-12-13-15-16-17-18 & 19		
9	02205461	O-RING 2.36 ID X .103 C/S		1
10	02206280	O-RING,2.487"ID X .103"CS		1
11	02205480	TURBINE HUB T 200 25/120		1
12	02203370	KEY 5 X 10		1
13	02205500	SHAFT,IMPELLER 25/120		1
14	02205510	KEY 6 X 50		1
15	02201670	BEARING,6204-2RS		1
16	02211820	SPACER DIA. 25 X 20 X 45.4		1
17	02201671	BEARING,5204-2RS		1
18	02203240	STOP RING I47		1
19	02201680	RETAINING RING E20		1

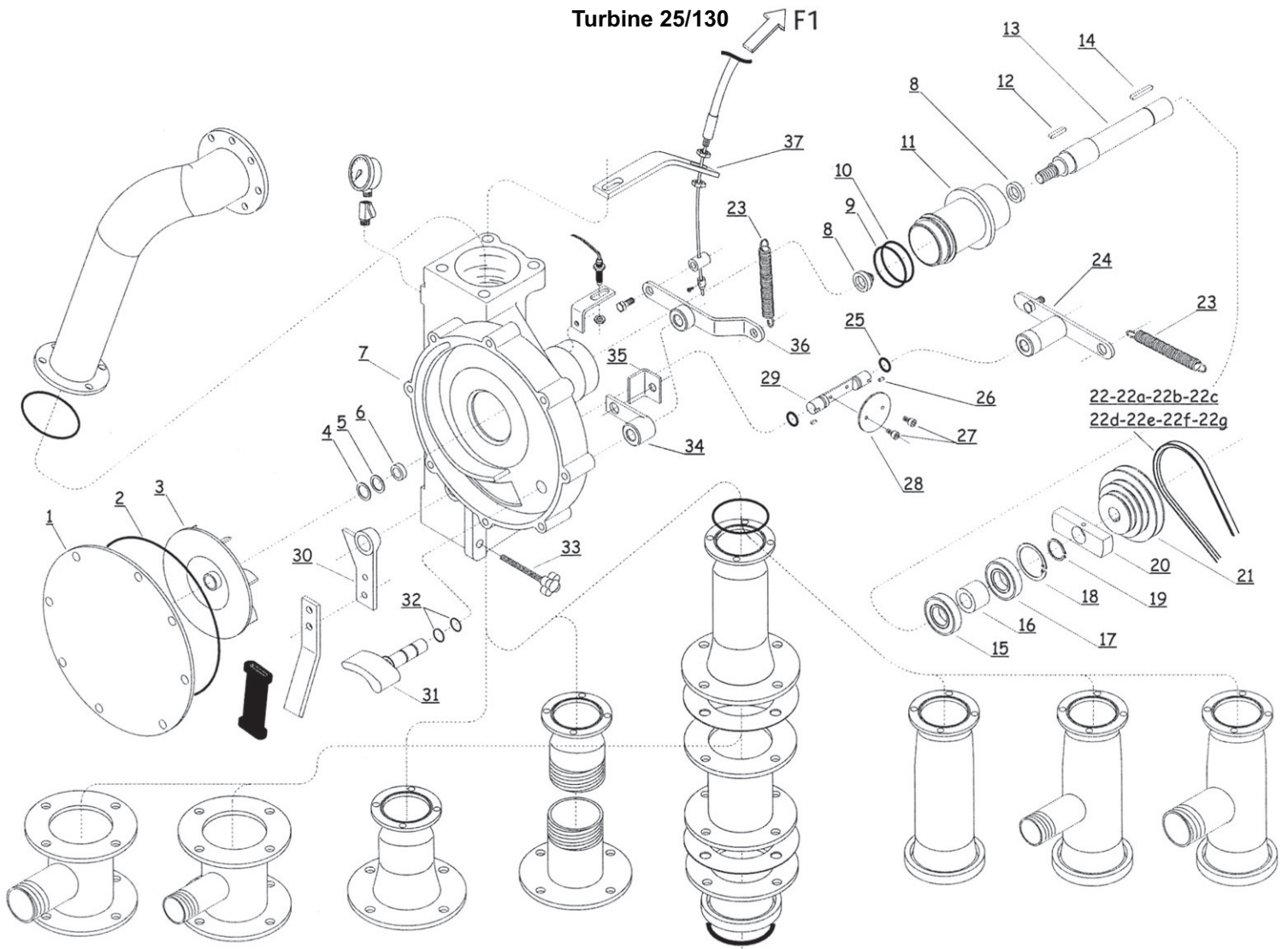

20	02218890	COMMAND PLATE SENSOR TURBINE		1
21	02205920	PLLY,100MM,75MM,53MM3STEP W/SETSCR		1
22	58408761	BELT, 4L71 OR A69		1
22a	58408762	BELT, 4L72 OR A70		1
22b	02205551	BELT, 4L73 OR A71		1
22c	02205553	BELT, 4L75 OR A73		1
22d	52651902	BELT,A55		1
22e	58401160	BELT,4L58 OR A56		1
22f	58401161	BELT,4L59 OR A57		1
22g	50201761	BELT, 4L62 OR A60		1
23	02203180	SPRING BELT TIGHTENER		1
24	02213770	LEVER, BYPASS		1
25	02205590	O-RING 15.54MM ID X 2.6MM		1
26	02216430	KEY 6		1
27	02203050	SCREW,6-1MM X 16MM		1
28	02205620	DISC,BY PASS		1
29	02205631	SHAFT,BYPASS W/GROOVES		1
30	02205580	LEVER, BY-PASS - 25/120		1
31	02205660	REGULATOR FLAP WITH PIN		1
32	02203310	O-RING 8.73MM ID X 1.78MM CS		1
33	02203910	HAND WHEEL		1
34	02206500	LOOP, COMPENSATOR - 10/50, 25/120		1
35	02217940	FLAP STOP		1
36	02211430	CONTROL LEVER FLAP		1
37	02211460	CABLE MOUNT		1

Turbine 25/130 F1

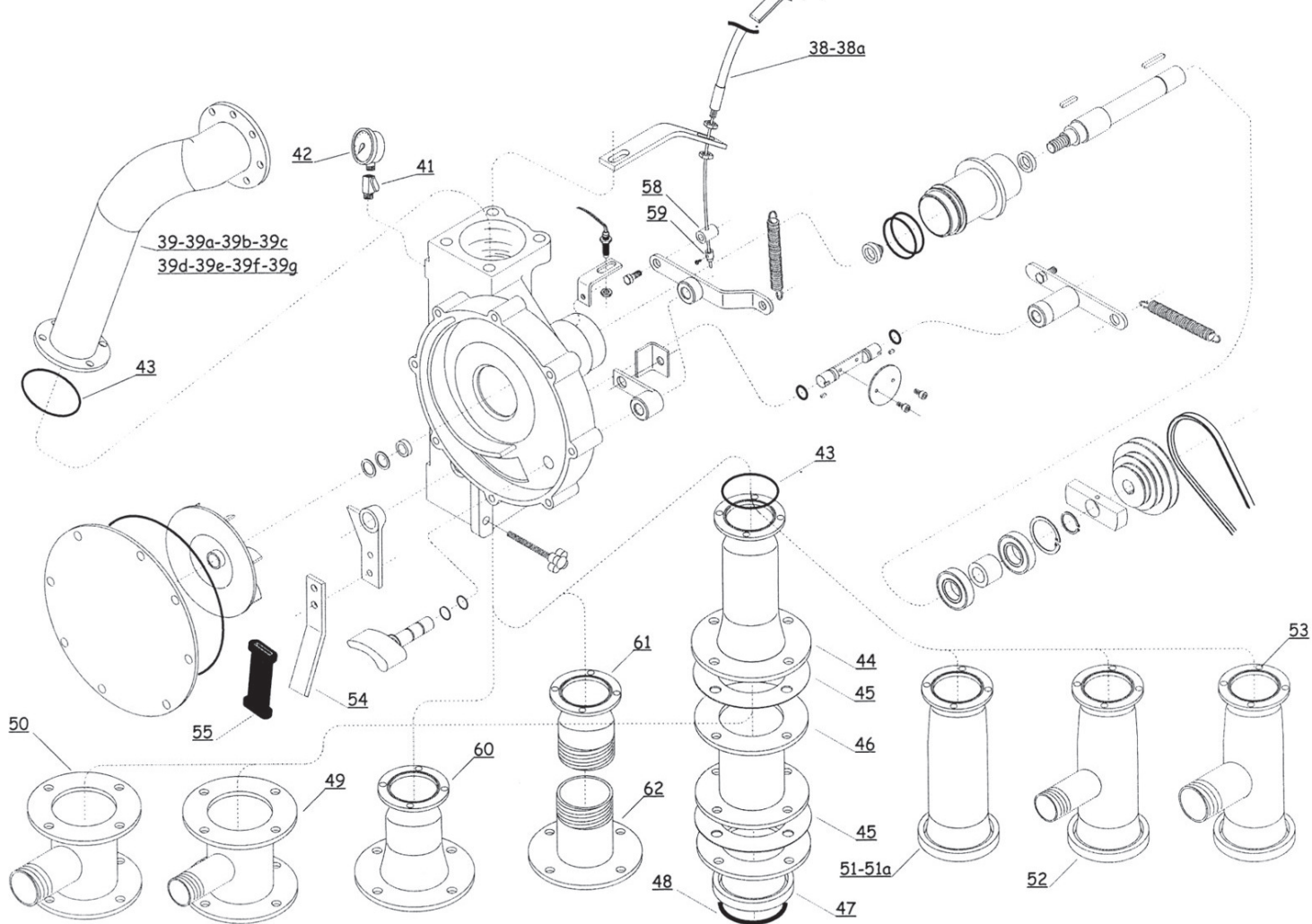

38	02211471	CABLE,COMP CONTROL(105")-AR4/5		1
38a	02211100	CABLE,COMPENSATOR CONTROL(120")-AR6/7		1
39d	02211151	ELBW,UPPER (BIMA BOX)-AR4		1
39e	02211841	ELBW,UPPER 8"FLNG TO WELD(BIMA)-AR5		1
39g	02212101	UPPER ELBOW W/BIMA GEAR BOX ST6/7		1
41	02217950	GAUGE COCK		1
42	58606750	GAUGE, PRESS 0-300		2
43	02204840	O-RING 104MM X 3.53MM		1
44	02217960	LOWER FEEDING ELBOW FOR VALVE		1
45	02217970	GASKET, DN80		1
46	02218930	NIPPLES WITH FLANGE		1
47	02217980	NIPPLES WITH FLANGE AND BAUER 4"		1
48	58800233	SEAL RING 4" 6-3/8 OD X 9/16		1
49	02217990	NIPPLE WITH FLANGE AND NIPPLE THREADED 1"1/2		1
50	02217991	NIPPLE WITH FLANGE AND NIPPLE THREADED 2"1/2		1
51	02217992	NIPPLE WITH FLANGE BAUR 3"1/2		1
51a	02204830	FITTING, ENTRY - 25/120 TURBINE 4" BAUER		1
52	02217993	NIPPLE WITH BAUR 3"1/2 W/NIP THREAD		1
53	02217994	NIPPLE WITH BAUR 4"W/NIP THREAD2"1/2		1
54	02205570	LEVER,BY-PASS		1
55	02204140	GRIP, TURBINE		1
56	02218000	SENSOR, SUPPORT		1
57	02213730	SENSOR, CRUISE CONTROL		1
58	02211450	CABLE ATTACHMENT		1
59	02218900	CABLE STOP		1
60		NIPPLE FOR VAS 3"		1
61		NIPPLE THREADED FOR VAS 4"		1
62		NIPPLE THREADED FOR VAS 4"		1

GUN CART ST4

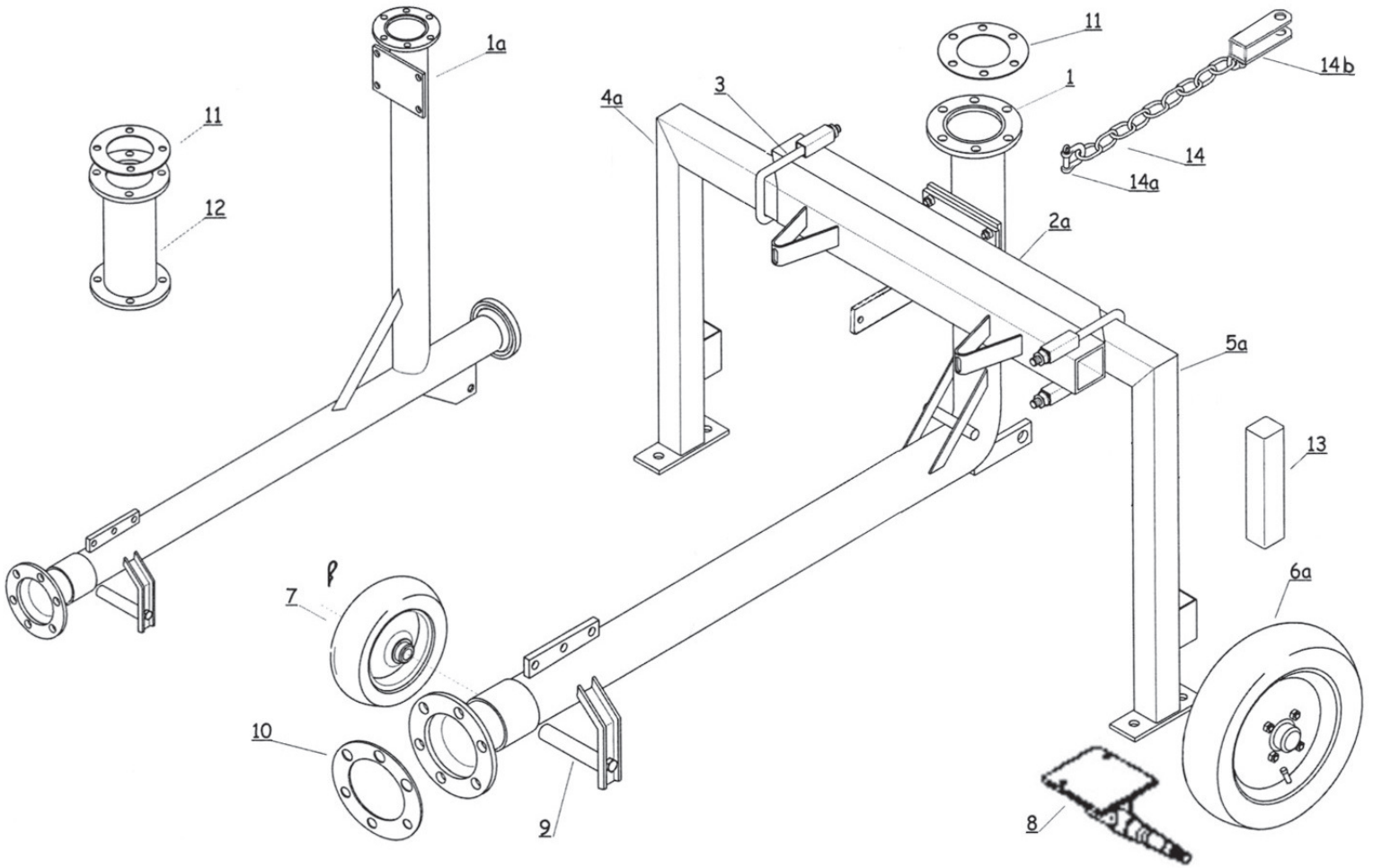

Item	Part Number	Description	Qty.
1a	02216531	BODY, GUNCART W/BALL PLUG FITTING	1
2a	02216541	LEGS SUPPORT	1
3	02216500	U-BOLT, M16	2
4a	02216511	LEG, LEFT	1
5a	02216521	LEG, RIGHT	1
6a	02210380	WHEEL TIRE ASSY R14-165	2
7	02218660	WHEEL, AND TIRE	1
8		SPINDLE	2
9	02216550	AXLE, FRONT GUNCART	1
10	02099202	GASKET, 5.75"BCD 4.3 ID	1
11	02000185	GASKET,RISER 5.12 BCD 3-1/2 ID	1
12	58406430	RISER EXTENSION 3-1/2X 12 (SR200)	1
13	02207150	WEIGHT	2
14	88040600	CHAIN,3/8 PROOF COIL ZINC PLATED	ft. 3
14a	52353941	CLEVIS,DBL CMBL 542-3301 (not as shown)	1
14b	52354210	HITCH, CHAIN	1

GUN CART ST 5-6-7

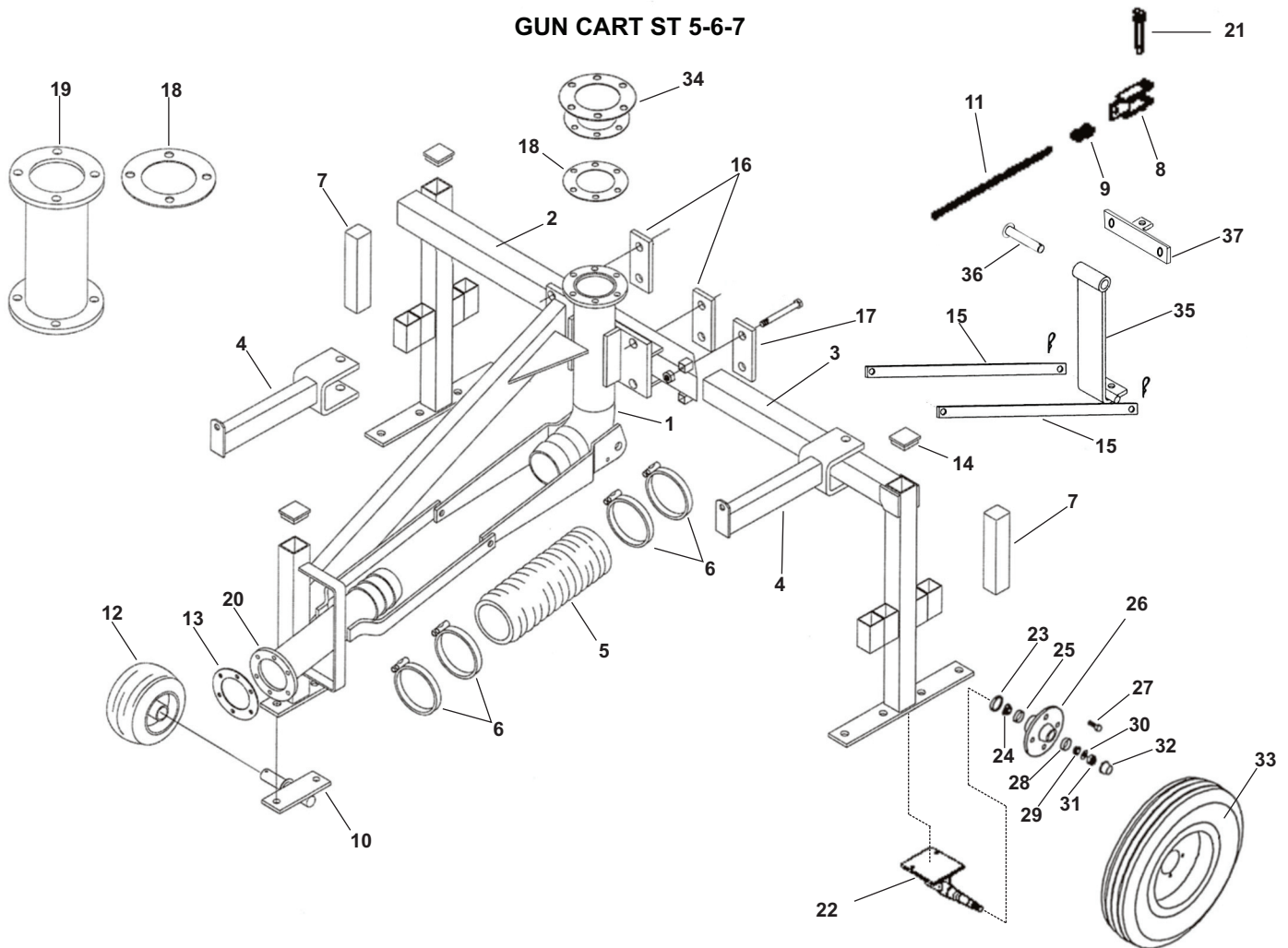

Item	Part Number	Description	Qty.
1	02209833	BODY, GUN CART MAIN FRAME - ST6/7	1
2	02209860	LEG, RIGHT, OFFSET, OUTER, 34" HGT.	1
3	02209870	LEG, LEFT, INLINE, INNER, 34" HGT.	1
4	02218590	CART STIRRUP COUPLER	2
5	02099111	HOSE 100 X 118MM, 33" LONG	1
6	03019240	SUPRA CLAMP 104MM-112MM	4
7	02207150	WEIGHT, CART BALLAST (2" OR 60MM)	2
8	52354210	HITCH, CHAIN	1
9	52353941	CLEVIS, DBL CMBL 542-3301	1
10	02212210	AXLE, GUNCART FRONT - AR6/7	1
11	85040600	CHAIN, 3/8 PROOF COIL PLTD	ft. 1.5
12	02209930	FRONT WHEEL 15.6.00/6" 4.50/6"U25	1
12a	02214780	BEARING, 6205 2RS	2
12b	02214790	SPACER, CART FRONT AXLE - A-SERIES	1
13	02099202	GASKET, 5.75"BCD 4.3 ID	1
14	02209950	CAP PLUG 7MM X 70MM	2
15	50201100	ARM GUNCART PULL	2
16	02209970	PLATE, CLAMP LARGE	2
17	02209980	CLAMP PLATE SMALL	1
18	02000185	GASKET, RISER 5.12 BCD 3-1/2 ID	1
19	58406430	RISER EXTENSION 3-1/2X 12 (SR200)	1
20	02210010	GUN CART BODY FRONT FOR 34" LEG CART	2
21	55832810	PIN, HITCH 3/4X3 T HEAD	1
22	02219840	SPINDLE ASSY. COMPLETE FOR FLEX BODY (spindle alone not available)	2
23	02219830	SEAL, FOR FLEX BODY CART	1
24/25	02203900	BEARING, TAPERED ROLLER 30204 (both race and bearing comes together)	1
26	02203911	HUB, WHEEL - AA	2
27	02203980	Lug Nut	8

GUN CART ST 5-6-7

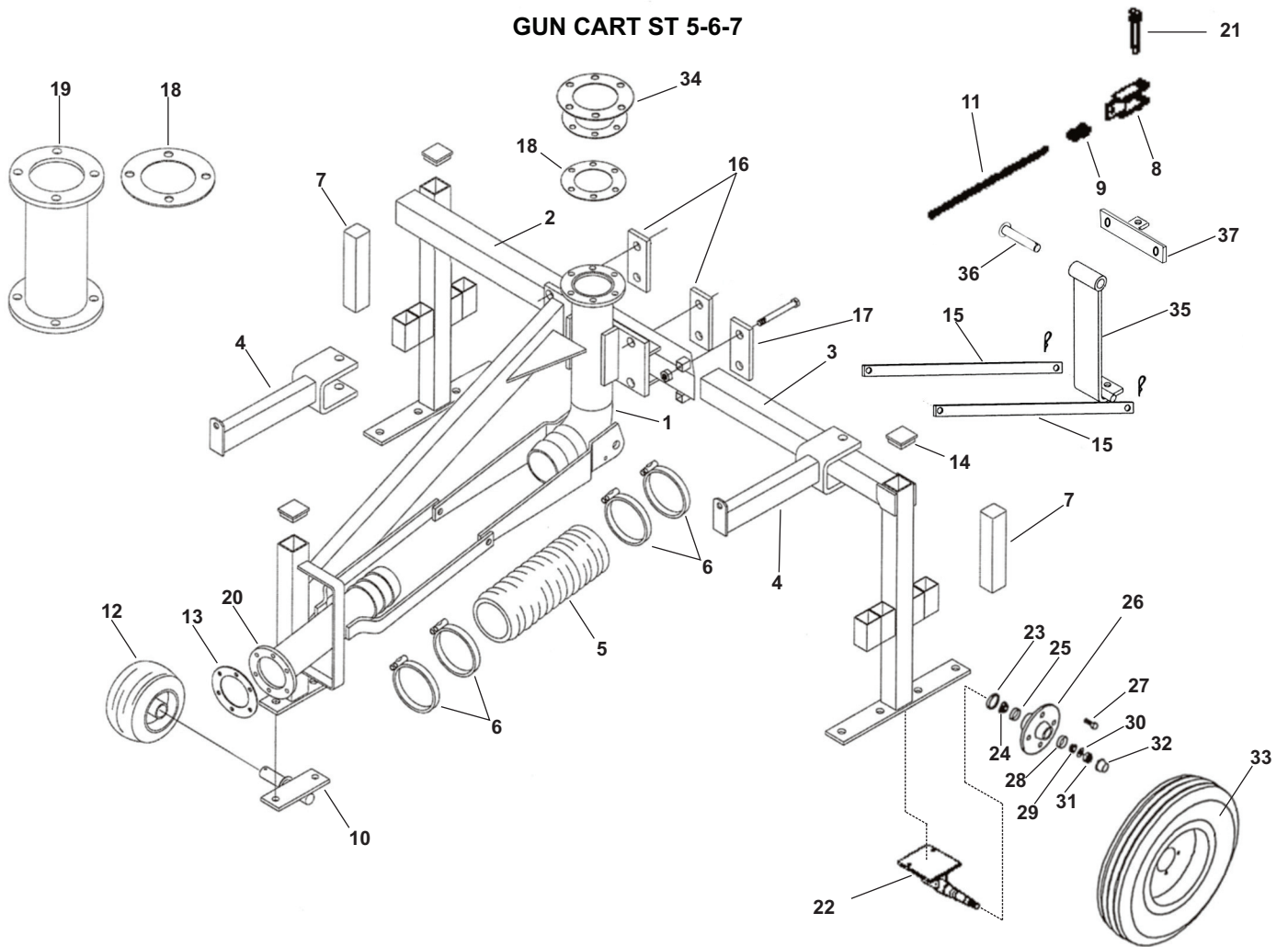

28/29	02203920	BEARING, TAPERED ROLLER 30205 (both race and bearing comes together)		2
30	55306280	BUSH, MACH 1-1/2X1X18GA		2
31	02203940	NUT, SPINDLE 18MMX1.5		2
32	02203950	DUST CAP		2
33	02210380	WHEEL TIRE ASSY R14-165		2
34	50104440	FLANGE, ADAPTOR GUN TO NELSON		1
35	50201140	DRAWBAR EXT.		1
36	02208940	PIN, 25MM X 170MM		1
37	50102680	BRACKET, CHAIN, STD1 GUNCART		1

18 HP Booster Pump Break Down

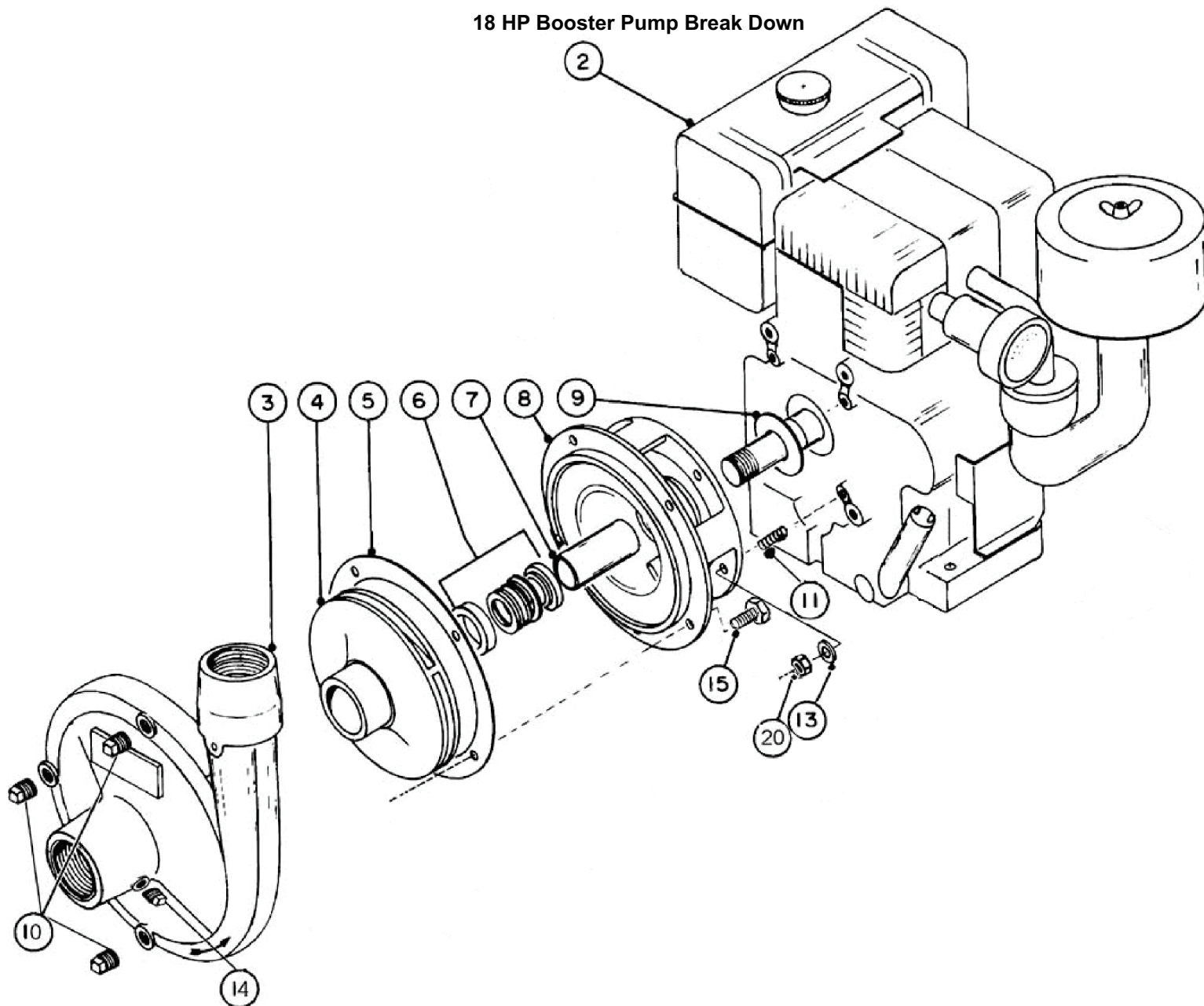

No.	Part Number	Description	Qty.
2		ENG,HONDA 18HP THREADED PUMP SHAFT	1
3	51000600	CASING, 2-1/2 X 2-1/2, 18HP PUMP	1
4	50802960	IMPELLER, 7.5 X 1" KEY SHAFT 18HP	1
5	51000610	GASKET, 18HP PUMP	1
6	59402531	SEAL,MECHANICAL 1-1/4"	1
7	59504171	SLEEVE,1-1/4 X 2.1" 8-1/2/9HP	1
8	51000620	ADAPTOR, 18HP PUMP	1
9	59402501	FLINGER, 8-1/2 AND 9 HP PUMPS	1
10		DRAIN PLUG	1
11		STUD	4
13		WASHER, LOCK	4
14		DRAIN PLUG	1
15		BOLT	4
20		Nut	4